

A proposal for Tape Recorders for the AT LBA

R.P.Norris
CSIRO Division of Radiophysics, PO Box 76, Epping,
NSW 2121, Australia.

Note: A preliminary version of this report was distributed on 30th January. The main difference between that version and this is the addition of Section 9: 'Impact on Correlator Design', and some minor changes throughout the text which result from the adoption of the coding scheme described in Section 9.

| | | |
|------|--|----|
| 1.0 | <u>SUMMARY</u> | 2 |
| 2.0 | <u>INTRODUCTION</u> | 3 |
| 2.1 | Scope and purpose of this report | 3 |
| 2.2 | Specifications | 3 |
| 2.3 | Bandwidth | 4 |
| 2.4 | Existing VLBI systems | 4 |
| 2.5 | How realistic are the cost estimates? | 5 |
| 2.6 | Overview of this proposal | 6 |
| 3.0 | <u>DATA ACQUISITION TERMINALS</u> | 7 |
| 3.1 | Overview | 7 |
| 3.2 | IF inputs | 7 |
| 3.3 | The formatters | 8 |
| 3.4 | Decoder/data buffer | 8 |
| 3.5 | The recorder | 8 |
| 3.6 | Cost Estimates | 9 |
| 4.0 | <u>DATA PLAYBACK TERMINALS</u> | 9 |
| 4.1 | Overview | 9 |
| 4.2 | The recorder | 10 |
| 4.3 | The decoder | 10 |
| 4.4 | The Correlator | 10 |
| 4.5 | Cost Estimates | 11 |
| 5.0 | <u>OVERHEADS</u> | 11 |
| 5.1 | Tape Usage | 11 |
| 5.2 | Hardware Replacement and Maintenance | 11 |
| 5.3 | Shipping | 11 |
| 5.4 | Manpower | 12 |
| 6.0 | <u>UNIFIED CLOCKS VS. CONVENTIONAL METHODS</u> | 12 |
| 7.0 | <u>THE PARKES-TIDBINBILLA RADIO LINK</u> | 13 |
| 8.0 | <u>THE TIED ARRAY</u> | 14 |
| 9.0 | <u>IMPACT ON THE CORRELATOR DESIGN</u> | 15 |
| 9.1 | Data Encoding | 15 |
| 9.2 | The Size of the LBA Correlator | 15 |
| 10.0 | <u>FUTURE EXPANSION</u> | 17 |
| 10.1 | Additional Narrowband Recorders | 17 |
| 10.2 | Wider bandwidths | 17 |
| 11.0 | <u>CONCLUSION</u> | 18 |
| | TABLE 1: SPECIFICATIONS | 20 |
| | TABLE 2: TAPE RECORDING DENSITIES | 21 |
| | TABLE 3: DAT COST ESTIMATES | 22 |
| | TABLE 4: DPT COST ESTIMATES | 23 |
| | TABLE 5: TOTAL CAPITAL COST | 24 |
| | TABLE 6: ANNUAL RUNNING COSTS | 24 |

1.0 SUMMARY

A detailed proposal for the implementation of tape recorders as a data transfer medium for the Long Baseline Array of the Australia Telescope is presented. This proposal is not intended to be a final specification, but instead represents a first iteration which will undoubtedly be greatly modified before the final specification is achieved. This proposed scheme is, however, considered in some detail, and the costs are evaluated as accurately as possible, so that it may be considered to be a workable and realistic guide to the feasibility and cost of such a system.

The conclusion is that VLBA-style recorders can be used to achieve the LBA specifications (and in some respects considerably exceed them) for a capital cost of A\$600k and an annual running cost of A\$60k. These figures do not include the cost of development work that will be needed at Radiophysics to develop the DAT control software, the DPT control software, and various interfaces (which are listed in the Conclusion). None of these areas, however, are expected to present problems that cannot be solved by existing AT staff.

The implementation described here would also enable the LBA to run at a bandwidth of 64MHz per telescope, with a reduced time between tape changes of 12h. It would also enable the future use of longer, thinner, tapes (which are expected to become available in the next few years) to run at 64MHz bandwidth with daily tape changes.

For a small additional sum (not yet determined but unlikely to exceed ~A\$50k), two portable narrow band (MkII) recorders and corresponding playback equipment could be provided so that we could make occasional use of telescopes such as Molonglo. The resulting data would be capable of being correlated with all the other LBA data.

2.0 INTRODUCTION

2.1 Scope and purpose of this report

The decision has now been made to use tape recorders for the transfer of data from the remote stations of the Long Baseline Array (LBA) of the Australia Telescope (AT) to the correlator at Culgoora. This decision also implies that terrestrial radio links to these remote stations will not be constructed, and that an alternative technique (such as satellite radio links or cryogenic sapphire-loaded cavities) must be used to ensure coherence between the LBA outstations. However, these phase stabilisation techniques are not the concern of this report, which is instead concerned only with the data transfer.

This report details a complete data transfer system using VLBI-style tape recorders. All costs have been included wherever possible, so that the total cost should include everything from where the data are handed over by the RF group to where the data are handed over to the correlator group. Thus this report gives a realistic working model which may be used as a basis for planning the necessary development and operation.

2.2 Specifications

The specifications of the data transfer system, which are listed in Table 1, include a bandwidth of 2 x 16MHz per telescope (the original bandwidth specification, as contained in AT/01.13/004d, was only 2 x 10MHz per telescope, but the extra bandwidth comes very cheaply) with a minimum time between tape changes (MTBTT) of 24 hours. These two criteria constitute a serious constraint to the design of the system, and mean, for example, that the widely-used MkII VLBI system (which has a bandwidth of 2MHz and a MTBTT of 4 hours) could not be used without considerable modification. A further constraint is implied by the desire to be compatible with other VLBI networks. The reasons for this are a) to minimise development costs and times, by using the expertise already gained elsewhere, and b) so that we can run collaborative experiments, and in particular use the proposed QUASAT satellite.

It should be noted that the specifications specifically allow for the inclusion of Hobart into the LBA network. Hobart was not in the original AT specifications, but it now seems likely that Hobart will be available for LBA use by 1988.

2.3 Bandwidth

The proposed system has a set of bandwidths (8MHz etc) which differ from those (10MHz etc.) of the compact array. The advantages of this are overwhelming:

1. We can use the standard filters constructed and designed for the VLBA.
2. We will be compatible with other VLBI systems.
3. We can use the tape to its maximum recording density.

One price that we pay for this is that the LBA bandwidths will differ from the CA bandwidths, so that a hypothetical map made from all the simultaneous baselines of the LBA and the CA would have large closure errors and degradation of sensitivity. However, there is no way, with the current correlator design, that such an observation could be made, so that this potential problem does not arise. A map made by combining the separate sets of uv data from the LBA and CA (but not invoking SELFCAL relations between them) would not suffer from such problems.

An additional price is that the data would normally be clocked into the correlator at 8MHz, whereas the correlator is currently being designed to run at 10 MHz. This is unlikely to be a problem. However, even if it was, then it could be overcome by running the playback machines at a different rate from the record machines. Such a difference in tape speed would normally be expected anyway for narrow-band observations, where the processing can be done at many times the record speed.

2.4 Existing VLBI systems

VLBI was pioneered simultaneously in the US, Canada, and in Europe, but since the early days of VLBI its technological progress has been driven by the US. Over the

last few years, VLBI has been dominated by two VLBI networks: the US network and the European VLBI network (EVN), although both have been based on equipment developed and built in the US. Until recently, both networks used the MkII system, which used commercial TV recorders (initially reel-to-reel and nowadays domestic cassette (VCR) recorders), and had a maximum bandwidth of 2MHz and a MTBTT of one to four hours.

The demands for increased sensitivity and bandwidth synthesis have now forced a changeover to the MkIII system, which uses a Honeywell model 96 instrumentation tape recorder. These tape recorders have 28 parallel tracks each of which is normally used at a bandwidth of 2MHz (although 4MHz operation is possible). The original MkIII system required tape changes every 13 minutes when used at this bandwidth, and was upgraded to the MkIIIa system by narrowing the tracks so that 12 sets of 28 tracks could be recorded on each tape, giving a MTBTT of 2.7 hours at 56MHz bandwidth. This is achieved by running the tape back and forth, recording on a different set of 28 tracks for each of the twelve passes. This upgrade was developed, and is being implemented, by Alan Rogers and his colleagues at the Haystack Observatory. The upgrade was originally planned for, and funded by, the NASA Crustal Dynamics Project, but most VLBI stations are now planning to instal the 'upgrade kit' produced by Haystack.

The planned US VLBA requires an even higher bandwidth and MTBTT, and so Haystack have designed a further upgrade for the VLBA. I will call this upgraded system the the MkIIIb system, since it is a straight-forward extension of the MkIIIa system. The MkIIIb will use even narrower tracks (allowing 32*24 tracks instead of 28*12), longer tapes, and slightly lower tape speeds, to achieve a MTBTT of 12 hours at 64MHz bandwidth, or 24h at a bandwidth of 32MHz. However, it is expected that the MkIIIa and MkIIIb tapes will be compatible in that tapes from either recorder can be processed on the same correlator, with only a small change to be made between systems.

2.5 How realistic are the cost estimates?

Some concern has naturally been expressed that the estimated cost of a complete VLBA Data Acquisition Terminal is estimated at less than \$100k, whereas recently Jodrell had to pay ~\$300k for a basic MkIII VLBI terminal (which has lower specifications than the VLBA terminal). To put this

disparity in perspective, it should be said that the lower estimate was made by the staff of Haystack Observatory, who were in the business of manufacturing and supplying MkIII terminals to other observatories before they were directed to hand it over to private industry. The terminals they made and sold were within their cost estimates, and the subsequent escalation occurred largely, it seems, because of commercial overheads and profit margins.

Haystack are still confident of their estimates, provided they manufacture the equipment (the VLBA itself would not be able to afford the above-mentioned commercial prices!). It should also be noted that the VLBA modules are generally cheaper than the corresponding MkIII modules because of reduced numbers of front-panel components (more is done in software), and the large quantities involved.

All the costs for VLBA modules are based on the cost to the VLBA. ~~Alan Rogers and his colleagues at Haystack have said (informally) that they would be willing to supply modules to us at the same price. Alternatively, they would be willing to give us the designs, diagrams, PC board layouts, etc.~~

2.6 Overview of this proposal

In order to minimise development effort and maximise ease of maintenance, the system proposed here makes maximum use of modules which are being developed for either the VLBA or the AT Compact Array. Thus in some cases modules which greatly exceed the LBA specifications are used in preference to redesigning a new module. This strategy also eases any future upgrades to the LBA. On the other hand, the high modularity of the VLBA electronics means that we can save some costs by omitting those modules whose functions are redundant to our needs.

The effect of this strategy is most apparent at the record end of the system, where very little development is needed: the VLBA Data Acquisition Terminals (DAT) will interface directly to the RF/LO subsystem designed for the AT. At the correlator end of the system some development will be needed to interface the playback electronics to the correlator.

3.0 DATA ACQUISITION TERMINALS

3.1 Overview

Figure 2 shows the block diagram of the Data Acquisition Terminal (DAT). It consists essentially of part of a standard VLBA terminal, with only trivial modifications. The IF distributors take an input in the range 492-1008MHz (only the segment 640-800MHz will be used for the AT) and distribute it to 4 baseband converters, each of which has independantly selectable local oscillators, enabling a high degree of versatility for bandwidth synthesis or multi-transition spectral line observations. Each baseband converter produces two output channels (USB and LSB), each of which contains (for the AT design) data which may subsequently be encoded on one to four tracks on the tape. The details of this encoding are discussed in Section 9 below. The formatter samples these data (selectable 1- or 2-bit) at one of eight selectable bandwidths in the range 0.0625-8MHz, and blocks and formats it for recording on the tape.

All the modules are standard VLBA modules, and the only modification is that there are fewer of these (generally by a factor of 4) than in the VLBA terminals. Each module contains a microprocessor which is addressed via a serial bus (RS-422). The amount of traffic over this bus is extremely modest, and might be driven by a single microprocessor or by the resident station computer.

One potential problem which has been explicitly ignored in this proposal is that it has been assumed that in principle RF can be transferred at 640-800MHz from the telescope to the DAT. Whilst this may not be a problem at some telescopes, it is likely to be a problem at Culgoora, requiring some additional development. Even at telescopes like Parkes, it may be advantageous to use a cable-length measuring system, such as has been designed for the VLBA. It will be necessary to investigate, as soon as possible, whether such a problem does actually exist (see Conclusion).

3.2 IF inputs

The VLBA IF distributors will accept any IF signal in the range 492-1008MHz, at a level between -42 and +22 dBm.

Such an IF signal is readily available in the current AT RF/LO chain after the 640-800MHz filter. Extracting the signal at this point means that:

1. No IF converters (other than the VLBA modules already described) will be needed for the LBA telescopes. The cost of two of these (currently estimated at ~A\$6000 each) may therefore be effectively deducted from the cost of the DAT for each telescope.
2. The 480MHz local oscillator from the Doppler Shifter/Reference Generator will no longer be in the IF chain, so that this cannot be used for Doppler corrections. The Doppler corrections on the other LO lines for LBA telescopes will need to be designed accordingly.

The VLBA DAT will use four IF distributors, each of which is a self-contained unit, feeding into sixteen baseband converters. The AT DAT will need only two IF distributors, and only 4 baseband converters.

3.3 The formatters

The VLBA will format 32 channels, whereas we will need to format only 8. The VLBA formatter consists of two units containing a number of identical boards. I have assumed that the cost is dominated by the boards (rather than the power supply, crate, etc.) and so have estimated the formatter cost at one quarter that of the VLBA.

3.4 Decoder/data buffer

The decoder/data buffer serves the function of checking encoded data, which is of use when checking and debugging, and of storing 4 Mbits of data for later slow transmission, so that we may check for fringes by using a narrow-bandwidth AUSSAT or Telecom channel.

3.5 The recorder

The recorder is a Honeywell Model 96, fitted with a special headstack (and associated electronics) by the staff of Haystack Observatory. The price of the basic transport

and associated control electronics is estimated by the VLBA at US\$21k, compared to the price quoted by Honeywell (Australia) of US\$40k in Australia. If Honeywell (or the Australian government) tried to persuade us to buy them here, we could reasonably argue that, since they needed modification at Haystack, we were not buying a standard item but instead were buying (from Haystack) an item that could not be bought locally.

3.6 Cost Estimates

Table 3 shows the estimated costs of individual items, based primarily on the budget submitted by Haystack to NRAO on 8 March 1984, covering the period 1 Jan 1984 to 31 Dec 1986. The prices in that document are given in FY85 US dollars. Applying an exchange rate of 0.82 gives a total price per DAT of 1985.0 A\$80k, or A\$68k if allowance is made for the two AT IF converters which would no longer be needed.

4.0 DATA PLAYBACK TERMINALS

4.1 Overview

Figure 3 shows a block diagram of the Data Playback Terminal (DPT). Its function is to take the data off the tape and clock them into the correlator at the appropriate time. The AT correlator, and in particular the 'unified clock' technique is well suited to this purpose, because tape speed variations require all VLBI processors to have a FIFO buffer. In the implementation proposed here, all such variations are left to the buffer in the correlator, so that the DPT becomes little more than a decoder.

It must be stressed that the playback side of the VLBA system does not yet seem to be in such an advanced state of design as the record side, and so the design details and cost estimates for the electronics are rather less certain. Fortunately, however, there is far less electronics in the DPT than in the DAT, and in fact the cost of the DPT is dominated by the recorder, whose cost is relatively certain.

Throughout this section, it has been assumed that the correlator will be clocking data at the same rate as that at which it was recorded. This assumption is made only for convenience, and there would be no reason why data should

not, for example, be sampled at 8MHz bandwidth in the DAT, and later played back at 10MHz bandwidth.

4.2 The recorder

The recorders are identical to those used for the DAT's, and all the comments made above (Section 3.5) apply equally to the DPT recorders.

4.3 The decoder

The decoder has the function of decoding the data from the frames on the tracks, checking for parity and other data errors, and then sending the data together with their clock to the correlator FIFO buffer. In the VLBA estimates, the decoder is lumped along with other electronics as 'deskew' electronics. Since the cost of most of this is proportional to number of channels, of which we have one quarter of those for the VLBA, I have arbitrarily taken one quarter of the VLBA estimate as the likely cost for the decoder electronics. Similarly, I have estimated the labour costs roughly pro rata with those for the DAT. It should be noted that in addition this area will require a certain amount of in-house development.

4.4 The Correlator

The output of the decoder will be a series of upto four data streams per telescope, each with a maximum clocking rate of 16MHz. Each stream will be associated with its own clock (for clocking into the buffer), validity bits (which may be used either to gate the correlator or else simply to flag faulty data), and messages on a communications link to give a reference time for the clock. In addition, messages from the correlator (or control computer) will be able to demand a particular time to be positioned at the tape heads. The details of the interface and protocol have not yet been decided for the VLBA, and so detailed designs for the AT must await those decisions if we are to maximise compatibility (and hence minimise cost). The correlator interface is discussed further in Section 9.

4.5 Cost Estimates

Table 4 shows the estimated costs of individual items, based primarily on the budget submitted by Haystack to NRAO on 8 March 1984, covering the period 1 Jan 1984 to 31 Dec 1986. The prices in that document are given in FY85 US dollars. Applying an exchange rate of 0.82 gives a total price per DPT of 1985.0 A\$46k.

5.0 OVERHEADS

5.1 Tape Usage

A one month tape supply is probably both necessary and adequate. Thus we will need an initial purchase of 150 tapes, which would currently cost about US\$38k, or A\$46k.

An estimate for tape replacement, based on VLBA figures, gives an annual tape replacement cost of A\$8k, assuming that the entire LBA is running for 50% of the time.

5.2 Hardware Replacement and Maintenance

Heads are expected to last about 10,000 hours, giving an annual head replacement cost of A\$6k. The estimated annual maintenance figure for the transports is estimated (based on VLBA figures) at A\$8k.

5.3 Shipping

The US VLB Network now considers ordinary parcel post to be adequate for shipping VLBI tapes, provided that the latter are packed in protective cartons. Assuming that each packaged tape weighs about 5kg, and that an average postal charge is 2\$/kg, gives an annual (two-way) postage bill of \$15k.

5.4 Manpower

Processing continuum observations involves the following daily tasks:

1. Dismount four tapes from previous day's processing. Erase, clean, and check them for damage. Post them back to the remote stations.
2. Check and clean tape transports.
3. Unpack and mount four new tapes.
4. Load instructions into control computer, to start processing.

Spectral line observations could, if desired, be processed at a faster-than-real-time rate. Doing so would increase the daily work load but, of course, reduce the length of the processing run accordingly.

In addition to these tasks at the processor, manpower would be needed each day at each remote site to:

1. dismount tapes from previous day, and post to Culgoora.
2. check and clean transport.
3. mount new tapes

It is estimated that these tasks, together with routine maintenance of hardware, will require one extra man at Culgoora, at an assumed salary of \$25k/year.

6.0 UNIFIED CLOCKS VS. CONVENTIONAL METHODS

There has been some debate within the VLBA over whether fringe rotation and delay should be applied at the telescope (as in the AT 'unified clock') or at the processor. It seems that, although no official decision has yet been made on this, the VLBA is likely to adopt the 'conventional' approach and apply delay (which is easy with VLBI tapes!) and phase rotation at the processor. Thus we probably have to decide whether to make the AT LBA follow

the VLBA approach or whether we make it look like the compact array. This issue needs to be studied in some depth before a decision is made. Some pros and cons are as follows:

For the unified clock:

1. The LO systems and correlators will be identical to those for the compact array.
2. No 'fractional bit shift correction' is needed at the processor. However, this correction could easily be done in software for our system, with little loss of sensitivity.
3. No phase rotator is needed at the processor, although a digital phase rotator immediately before the correlator is a relatively minor addition.

Against the unified clock:

1. The tapes will not be identical to VLBA tapes, and will need to be processed differently (It may be possible to effect the change entirely in software on the VLBA processor).

It would be premature to make this decision now (especially since the VLBA may yet go for the 'unified clock' approach), and so in this proposal I have assumed that we will use the unified clock for the LBA. This option is conceptually the simplest, and so is a good starting point for a preliminary study such as this.

The difference in hardware between the two systems is not great for VLBI, since most of the delay compensation occurs in the tape alignment, and phase rotation may be done digitally immediately before correlation. Thus the cost is not likely to be very much greater even if we did adopt the VLBA scheme, and this could even be retro-fitted as a switchable option on the LBA.

7.0 THE PARKES-TIDBINBILLA RADIO LINK

Since a radio link already exists between Parkes and Tidbinbilla, we can save the expense of an additional Data Acquisition Terminal (DAT) by transferring the Tidbinbilla data to Parkes and recording them on the Parkes DAT along

with the Parkes data. This presents no bandwidth problems, since we will be running the DAT's well below their maximum bandwidth, and simply means that we will have to change the tapes at Parkes twice as often as at the other stations. This also presents few problems since Parkes is unlikely to operate as an unmanned station in the foreseeable future.

This approach is made particularly practicable by the data/clock concept used by the VLBA system. Provided that the data sent from Tidbinbilla are accompanied by their 'clock', no notice need be taken of the propagation delay from Tidbinbilla to Parkes. This is, of course, identical to the argument for the 'unified clock' approach, and reflects the conceptual similarity between the two systems. The association between clock and data might be achieved with either analogue or digital data. In the latter case, the process could be achieved particularly neatly by locating the DAT converter and formatter modules at Tidbinbilla, and then sending the formatted data up the link. The Tidbinbilla tracks would then lag the Parkes tracks by a few ms (each track has its own, independent, clock), which would automatically be removed in the delay at the correlator.

To use this radio link will of course require a certain amount of development. Some of this development will occur during the construction of the Parkes-Tidbinbilla interferometer within the next year. The cost of developing it to the standard required for the AT has not yet been calculated and so is explicitly omitted from the final costings (see Conclusion).

Finally, it should be noted that although this link is suitable for data transfer it cannot be used for local oscillator transfer, so an additional frequency/time standard (such as the existing Hydrogen maser at Tidbinbilla) will still be required.

8.0 THE TIED ARRAY

Since the details of how the Compact Array is to be 'tied' for the LBA have not yet been specified, it is not yet possible to assess the difficulty of interfacing the tied array to the DAT. At first sight, however, there appear to be no special problems, although some development will undoubtedly be needed for any implementation of the tied array. For the purposes of this proposal, the LBA is assumed to use just one CA antenna (see Conclusion).

9.0 IMPACT ON THE CORRELATOR DESIGN

9.1 Data Encoding

A coding scheme for 1-bit sampling of maximum bandwidth data is as follows. The 16MHz passbands are split into two (USB and LSB) 8MHz bands by the baseband converters, and each of these 8MHz bands are then sampled at 16Mbit/s. The sampled data cannot be encoded directly on the tape tracks, which have a maximum bandwidth of 8Mbit/s. Instead, the samples are distributed over two tracks: odd samples on one; even on the other. This configuration is supported by the VLBA modules, which also allow a corresponding distribution over four tracks (primarily for 2-bit sampling). The coded data are then suitable, on playback, for interfacing directly to the correlator.

9.2 The Size of the LBA Correlator

A significant difference from the point of view of the correlator between the system proposed here and that originally planned for the AT is that each telescope IF is now split into two channels. Since only corresponding channels must be correlated, this seems to imply an increase (by a factor of two) in the number of correlator modules needed. However it should be noted that:

1. The problem arises only when operating at maximum bandwidth. When operating at 8MHz bandwidth per telescope IF or below, there need be only one data stream (which may be encoded over two tape channels) per telescope IF channel.
2. Many observations (e.g. spectral line) will not use the LBA at full bandwidth, and the LBA itself will not be used for 100% of the available time. Thus there is likely to be sufficient processing time to process the full bandwidth observations in two passes.

Possible solutions include:

1. Double the number of correlator channels. (Pro: easy and convenient; Con: expensive)
2. Process all full bandwidth observations in two passes. (Pro: cheap; Con: inconvenient and increased running costs because of head and tape wear)
3. Reconfigure the correlator modules for the LBA (Con: more development manpower needed)
4. Digitally add the two 16Mbit/s streams (after rotation of one), so they can then be input to correlator as one stream. (Con: ~ 30% loss of signal-to-noise assuming 1 bit sampling)

The proposed solution is a combination of the above alternatives. First, it should be noted that the current LBA correlator design is initially for only 6 baselines (4 telescopes). However, by 1988 Hobart is likely to be available for some of the time, and so I propose that the initial correlator design should be for at least 10 baselines (5 telescopes). If in fact we design it for 12 rather than 10 baselines, then we have the capability for one-pass processing of the following types of data:

1. 4 telescopes at maximum bandwidth (2 * 16MHz per telescope)
2. 5 telescopes at lower bandwidths (2 * 8MHz per telescope and below).

On those (probably rare) occasions when all five telescopes were used at maximum bandwidth, the data would have to be processed in two passes.

In summary, the potential correlator problem is circumvented if we construct the LBA correlator for 12 (rather than 6) baselines, and if we utilise the VLBA facility of encoding 16Msample/sec data over two tape tracks.

10.0 FUTURE EXPANSION

10.1 Additional Narrowband Recorders

A possible enhancement to the system described would be the addition of two portable narrowband terminals plus the corresponding playback equipment. These narrow-band DAT's (henceforth NDAT) could be exact replicas of conventional MkII VCR terminals. Thus little development would be needed, since the (well-tried) circuits for these are readily available. Each terminal could include a Rubidium frequency standard, which would be quite satisfactory for the low frequencies (< 3GHz) likely to be observed (e.g. at Molonglo) with these terminals.

The playback system would use a narrow-band data playback terminal (NDPT), which would essentially decode the MkII tapes, and also drive the VCR's, so that the NDPT's look like standard MkIII DPT's to the correlator. A unit which performs this function for 16 NDPT's has been designed, and is being built, by the Caltech VLBI group. The expected cost, for 16 VCR's, is expected to be in the region of \$10k. We would need to build only a sub-section of this device.

At the time of writing this report, the cost of this additional system has not been evaluated, although an educated guess would place the total cost at less than \$50k.

10.2 Wider bandwidths

The implementation described here would allow the LBA to be used at a maximum bandwidth of 64MHz, at a reduced MTBTT of 12h. Such data could then be processed with the available correlator capacity by processing each tape in two passes. It is also expected that longer, thinner, tapes are likely to become available in the next few years, which would enable a 24h MTBTT at 64MHz bandwidth. Furthermore, additional modules could be added at a relatively small incremental cost to allow even wider bandwidths (upto 128MHz per telescope) at a proportionally shorter MTBTT.

11.0 CONCLUSION

The system adopted for the VLBA seems eminently suitable for the AT. Adoption of this system (which is likely to become the international VLBI standard for some years hence) for the AT means that

1. The AT LBA will be compatible, not only with the VLBA, but also probably with any other VLBI networks set up during the lifetime of the AT. In particular, we will be able to make use of the QUASAT satellite.
2. We can minimise our development costs, by relying on expertise developed elsewhere.
3. We may be able to minimise the capital cost by having equipment constructed at the same time as the VLBA, thus gaining extra discounts for quantity.

This system exceeds the original AT specification in various respects, and in particular allows a greater degree of flexibility than was originally required. It also specifically includes Hobart as part of the LBA network. Furthermore, future expansion to wider bandwidths or extra stations is easily accomplished with this system.

The capital cost of the system (estimated at about A\$600k for the entire data path from telescope IF to correlator input, but excluding some development that will be needed to be done within the AT) is within the allocated budget.

The implementation of the scheme will require work in the following areas:

1. Control Software for the DAT, to be resident on the remote telescope main control computer.
2. Control Software for the DPT, to be resident on the correlator VAX.
3. Development of an interface between the DPT and the correlator. This must await the final decision on the VLBA interface.

4. Development of a technique for tying the compact array, and interfacing it to the DAT.
5. Development of a technique for transferring the data over the radio link from Tidbinbilla to Parkes.
6. Investigation of potential problems in transferring the IF signal from the telescope to the DAT (see Section 3.1).

It is recommended that these developments should be started as soon as possible.

12.0 TABLE 1: SPECIFICATIONS

Data to be recorded at each of four stations (Culgoora, Siding Spring, Parkes, and Hobart), transferred to Culgoora, and tapes from all stations to be replayed there simultaneously. Data from Tidbinbilla to be sent to Parkes over the microwave link, and recorded on the Parkes recorder. Buffered sample of data to be available for slow replay over narrowband line for real-time fringe detection.

| | |
|--------------------------------------|---|
| IF streams per telescope: | 2 |
| Max Bandwidth per IF stream: | 16MHz |
| Max no. of indept. channels per tel. | 4 |
| Available bandwidths per channel | 0.0625, .125, .25, .5, 1, 2, 4, 8MHz |
| Min. time between tape changes: | 24 hours (12h at Parkes) |
| Input from telescope IF: | in range 640-800MHz, selectable by internal synthesiser Level in range -42 to +22 dBm |
| Output to correlator: | 2-8 digitised data streams/telescope, + associated clocks and validity bits |
| DAT Control: | via RS422 bus from telescope computer |
| DPT Control: | via bus from synch. VAX, plus timing signals from corr. |

13.0 TABLE 2: TAPE RECORDING DENSITIES

This table gives the recording density for various configurations of MkIII/VLBA type recorders, and is included because there are several misunderstandings and inconsistencies scattered throughout the VLBI and VLBA literature. The table below, which is based on information from the horses' mouths at Haystack, gives definitive values for the MkIII and MkIIIa systems. For the other systems, it should be noted that this table shows only a representative sample of the spectrum of different combinations of tape speeds, bandwidths, and MTBTT.

| Type | Tape Speed | Tape Length | No. of Tracks | BW per Track | Total BW | MTBTT |
|--------|------------|-------------|---------------|--------------|----------|-----------|
| MkIII | 270ips | 9200 | 28 | 4MHz | 112MHz | 6.8 mins |
| MkIII | 135ips | " | " | 2MHz | 56MHz | 13.6 mins |
| MkIIIa | 135ips | " | 12*28 | 2MHz | 56MHz | 2.7 hours |
| MkIIIb | 180ips | 13500 | 24*32 | 4MHz | 128MHz | 6 hours |
| MkIIIb | 90ips | 13500 | 24*32 | 2MHz | 64MHz | 12 hours |
| AT | 180ips | " | 24*4*8 | 4MHz | 32MHz | 24 hours |

A normal AT continuum observation would have 2 * 16MHz channels per telescope converted to four 8 MHz baseband channels, each of which would be encoded (by odd/even splitting) onto 2 * 8Msample/sec tracks, so that only 8 tracks would be used per tape pass. These would be used by the correlator on playback as 4 16Msample/sec channels.

Note that the same hardware will support twice the bandwidth. In that case, four 16MHz input channels would be converted to 8 * 8MHz baseband channels, which would then be encoded as 16 * 8Msample/sec tracks.

14.0 TABLE 3: DAT COST ESTIMATES

The totals shown are for one Data Acquisition Terminal (DAT). Prices are based on VLBA Memos and reports (see text), and are in FY85 US\$.

| Item | Unit Price | Qty | Cost |
|-----------------------|------------|------|-----------|
| IF distributors | 1000 | 2 | 2000 |
| Baseband converters | 2500 | 4 | 10000 |
| Formatters | 5000 | 1 | 5000 |
| Decoder/data buffer | 3000 | 1 | 3000 |
| Rack & Power Supplies | 5000 | 1 | 5000 |
| Model 96 transport | 15000 | 1 | 15000 |
| Recorder electronics | 6000 | 1 | 6000 |
| Headblock | 4000 | 1 | 4000 |
| Labour (Electronics) | 10000 | | 10000 |
| Labour (Recorder) | 6000 | | 6000 |
| TOTAL | | 1985 | US\$66000 |

Assuming 1A\$ = US\$0.82 gives

TOTAL COST PER DAT = 1985.0 A\$80k

(N.B. effective cost = A\$80k - 2*(cost of AT IF converter)
= A\$68k)

15.0 TABLE 4: DPT COST ESTIMATES

The totals shown are for one Data Playback Terminal (DPT). Prices are based on VLBA Memos and reports (see text), and are in FY85 US\$.

| Item | Unit Price | Qty | Cost |
|-----------------------|------------|------|-----------|
| Decoder | 4000 | 1 | 4000 |
| Rack & Power Supplies | 5000 | 0.2 | 1000 |
| Model 96 transport | 15000 | 1 | 15000 |
| Recorder electronics | 6000 | 1 | 6000 |
| Headblock | 4000 | 1 | 4000 |
| Labour (Electronics) | 2000 | | 2000 |
| Labour (Recorder) | 6000 | | 6000 |
| TOTAL | | 1985 | US\$38000 |

Assuming 1A\$ = US\$0.82 gives

TOTAL COST PER DPT = 1985.0 A\$46k

16.0 TABLE 5: TOTAL CAPITAL COST

All prices in 1985 A\$.

| | |
|--|---------|
| 4 Data Acquisition Terminals (DAT) @ 80k | 320k |
| 4 Data Playback Terminals (DPT) @ 46k | 184k |
| 1 extra DAT electronics for Tidbinbilla | 43k |
| 1 extra DPT electronics for Tidbinbilla | 9k |
| 1 months supply of tapes | 46k |
| TOTAL | A\$602k |

17.0 TABLE 6: ANNUAL RUNNING COSTS

All prices in 1985 \$A.

| | |
|-----------------------|-------------|
| Tape replacement | 8k |
| Head replacement | 6k |
| Transport maintenance | 8k |
| Shipping | 15k |
| Manpower | 25k |
| TOTAL | A\$62k/year |

APPENDIX A

GLOSSARY

- AT The Australia Telescope, which comprises both the CA and the LBA.
- CA The Compact Array of the Australia Telescope, which comprises six 22m dishes on a 6km E-W baseline at Culgoora.
- DAT Data Acquisition Terminal. This comprises the tape recorder, all associated electronics, filters, converters, etc.
- DPT Data Playback Terminal. This comprises the tape transport, decoder, and interface to the correlator.
- EVN The European VLBI Network
- LBA The Long Baseline Array of the Australia Telescope. This comprises the Compact Array at Culgoora, the 64m telescope at Parkes, and a new 22m telescope to be built at Siding Spring. In addition, it is expected that the telescopes at Tidbinbilla and Hobart will frequently participate in LBA observations.
- MkII The VLBI system widely used until recently. Most terminals use a domestic VCR, and have a max bandwidth of 2MHz and a MTBTT of 4 hours.
- MkIII The VLBI system that replaced MkII. Uses a Honeywell 96 tape recorder, has a max bandwidth of 112MHz, but is normally used with a bandwidth of 56MHz and a MTBTT of 13 mins.
- MkIIIa A modification of the MkIII system which has a MTBTT of 2.6h at 56MHz bandwidth.
- MkIIIb The name I have chosen to use for the system planned for the VLBA. It is a modified MkIIIa system with a MTBTT of 12h at a max bandwidth of 64MHz.
- MTBTT Minimum time between tape changes
- VLBA The Very Long Baseline Array planned for the US, with a completion date that was originally 1988 but is now slipping, probably by a few years, for budgetary reasons.

APPENDIX A

POTENTIAL PROBLEMS NOT COVERED IN THIS REPORT

AREAS

in this report

There are some areas which have not yet been studied, largely because the necessary details are not yet available. The costs presented here do not therefore include any costs (financial or manpower) associated with the following areas:

1. The Parkes-Tidbinbilla Radio Link. It has been assumed that the data can be transferred for Tidbinbilla to Parkes with little extra development.
2. The Tied Array. Since the details of how this is to be implemented are not yet decided, the problem has been ignored by assuming, for the present, that the LBA will use only one telescope at Culgoora.
3. Transfer of the RF signals from the telescope to the DAT. It has been assumed that in principle RF can be transferred at 640-800MHz from the telescope to the DAT. Whilst this may not be a problem at some telescopes, it is likely to be a problem at Culgoora, requiring some additional development. Even at telescopes like Parkes, it may be advantageous to use a cable-length measuring system, such as has been designed for the VLBA.

11.0 TABLE 5: TOTAL CAPITAL COST

All prices in 1985 A\$.

| | |
|--|---------|
| 4 Data Acquisition Terminals (DAT) @ 80k | 320k |
| 4 Data Playback Terminals (DPT) @ 46k | 184k |
| 1 extra DAT electronics for Tidbinbilla | 43k |
| 1 extra DPT electronics for Tidbinbilla | 9k |
| 1 months supply of tapes | 46k |
| TOTAL | A\$602k |

TABLE 6
 12.0 ANNUAL RUNNING COSTS

All prices in 1985 \$A.

| | |
|---|--------------------------|
| Tape replacement | 8k |
| Hardware replacement / <i>manpower</i> | 17k <i>6k</i> |
| Head replacement / <i>leave</i> | 15k ✓ |
| Shipping | |
| Manpower | 25k |
| TOTAL | A\$63k/year |

2

APPENDIX A

POTENTIAL PROBLEMS NOT COVERED IN THIS REPORT AREAS

There are some areas which have not yet been studied, largely because the necessary details are not yet available. The costs presented here do not therefore include any costs (financial or manpower) associated with the following areas:

1. The Parkes-Tidbinbilla Radio Link. It has been assumed that the data can be transferred for Tidbinbilla to Parkes with little extra development.
2. The Tied Array. Since the details of how this is to be implemented are not yet decided, the problem has been ignored by assuming, for the present, that the LBA will use only one telescope at Culgoora.
3. Transfer of the RF signals from the telescope to the DAT. It has been assumed that in principle RF can be transferred at 640-800MHz from the telescope to the DAT. Whilst this may not be a problem at some telescopes, it is likely to be a problem at Culgoora, requiring some additional development. Even at telescopes like Parkes, it may be advantageous to use a cable-length measuring system, such as has been designed for the VLBA.

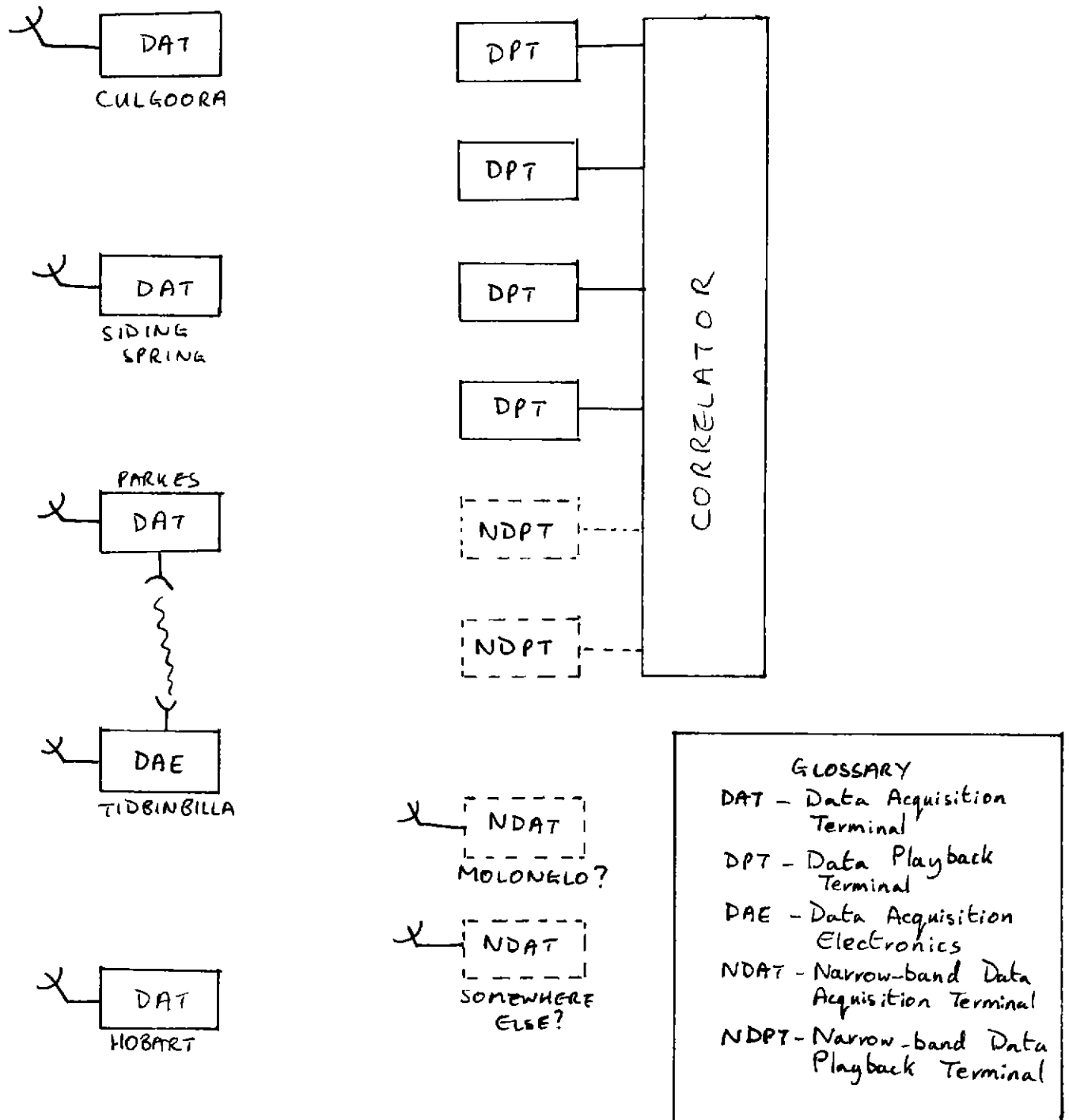

FIG 1: OVERVIEW

11.0 TABLE 5: TOTAL CAPITAL COST

All prices in 1985 A\$.

| | |
|--|---------|
| 4 Data Acquisition Terminals (DAT) @ 80k | 320k |
| 4 Data Playback Terminals (DPT) @ 46k | 184k |
| 1 extra DAT electronics for Tidbinbilla | 43k |
| 1 extra DPT electronics for Tidbinbilla | 9k |
| 1 months supply of tapes | 46k |
| TOTAL | A\$602k |

TABLE 6
 12.0 ANNUAL RUNNING COSTS

All prices in 1985 \$A.

| | |
|------------------------------------|------------------|
| Tape replacement | 8k |
| Tape transport | 8k |
| hardware replacement | 17k |
| head replacement / <i>manpower</i> | <i>6k</i> |
| <i>leave</i> | |
| Shipping | 15k ✓ |
| Manpower | 25k |
| TOTAL | A\$65k/year |

2

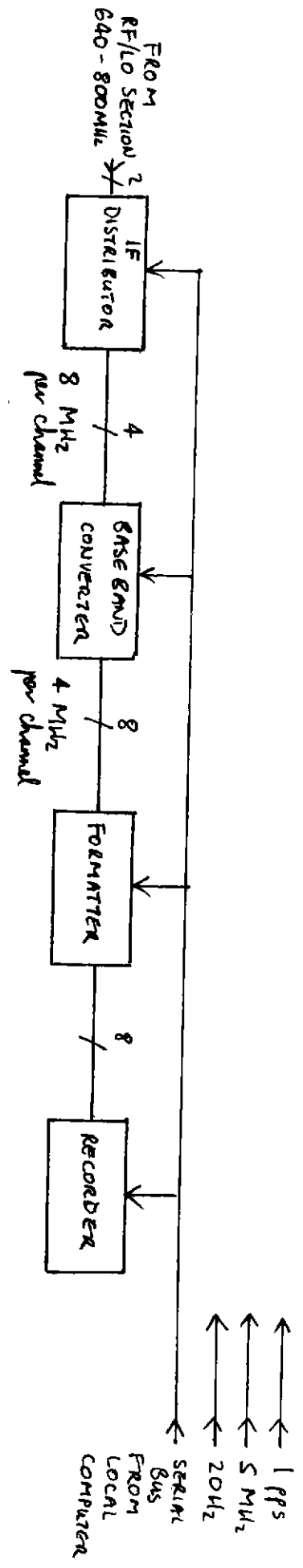

FIGURE 2: TUE DATA ACQUISITION TERMINAL

10.0 TABLE 4: DPT COST ESTIMATES

The totals shown are for one Data Playback Terminal (DPT). Prices are based on VLBA Memos and reports (see text), and are in FY85 US\$.

| Item | Price Each | Qty | Cost |
|-----------------------|------------|-----|----------------|
| Decoder | 4000 | 1 | 4000 |
| Rack & Power Supplies | 5000 | 0.2 | 1000 |
| Model 96 transport | 15000 | 1 | 15000 |
| Recorder electronics | 6000 | 1 | 6000 |
| Headblock | 4000 | 1 | 4000 |
| Labour (Electronics) | 2000 | | 2000 |
| Labour (Recorder) | 6000 | | 6000 |
| TOTAL | | | 1985 US\$38000 |

Assuming 1A\$ = US\$0.82 gives

TOTAL COST PER DPT = 1985.0 A\$46k

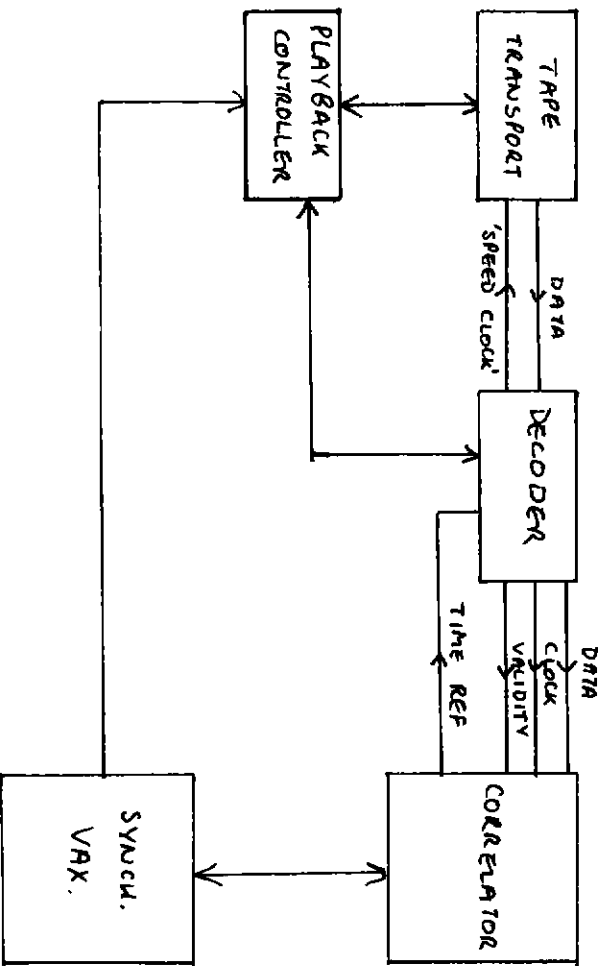

FIGURE 3: THE DATA PLAYBACK TERMINAL

TELEX MESSAGE TELE
TELEX MESSAGE TELE

attach to ~~1773~~ AT/17.3.1/003

FILE
96
96
96

GA
020
INTLX 0306 0417
ASTRO AA26230
GA
230948149+
RCA MAR 23 1985
HAYSTACK WFRD

ASTRO AA26230

6/3/85

TO: ALAN ROGERS, HAYSTACK OBSERVATORY
FROM: RAY NORRIS, CSIRO RADIOPHYSICS

MANY THANKS FOR YOUR HELP AND HOSPITALITY DURING MY TRIP TO HAYSTACK.

I HAVE NOW COMPILED A REPORT PROPOSING A CONFIGURATION FOR THE AT, AND AM SENDING YOU A COPY. IN THAT REPORT, I MENTION THAT YOU HAVE INDICATED INFORMALLY THAT YOU WOULD BE WILLING TO SUPPLY VLBA MODULES AT THE SAME COST AS TO THE VLBA, OR ELSE LEND US DIAGRAMS, ETC. ARE YOU HAPPY FOR THIS STATEMENT TO REMAIN IN THE REPORT, WHICH WILL BE DISTRIBUTED OUTSIDE RADIOPHYSICS, INCLUDING SOME PEOPLE AT NPAO?

BEST WISHES
RAY NORRIS

*
-HAYSTACK WFRD

ASTRO AA26230

TELEX MESSAGE TELE
TELEX MESSAGE TELE

10

10