

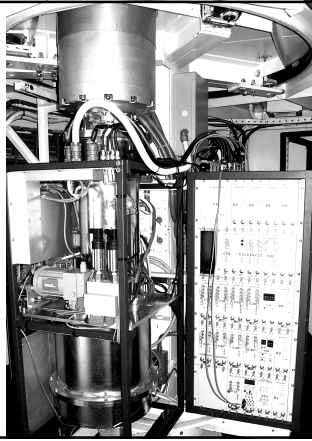

**Compact Array  
Antenna  
Vertex Room**

- 20/13cm dewar and receiver system
- Bottom portion of the 20/13cm band horn
- Conversion rack on right



**Receiver Front-End  
Block Diagram**

- Horn
- Noise injection coupler
- Cryogenically cooled components
  - Polariser
  - Bandsplitters
  - Low-noise amplifiers
- Ambient temperature gain
- Control and monitoring

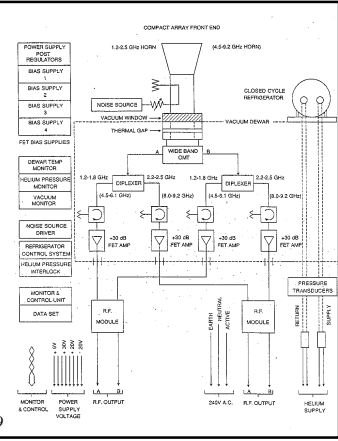

**Receiver:  
6/3 cm band**

- Gap waveguide
- Polariser
- Bandsplitters
- Low-noise amplifiers
- 20 Kelvin cold plate

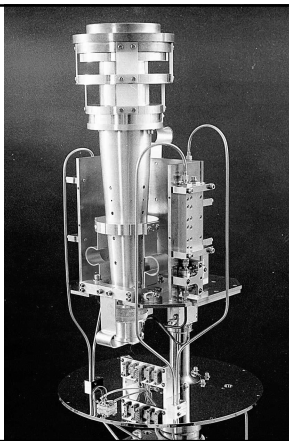

**Receiver:  
6/3 cm band**

- Gap waveguide
- Polariser
- Bandsplitters
- Low-noise amplifiers
- Cryogenic refrigerator

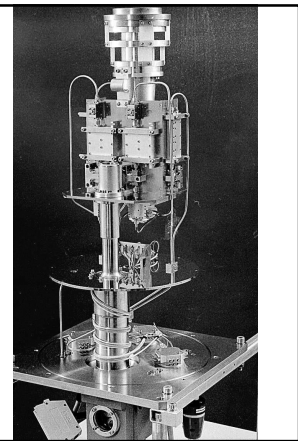

**Receiver:**  
6/3 cm band

**Low-Noise Amplifiers**

- 3 high-electron-mobility transistors (HEMTs)
- Input matching network
- Internal wall to reduce cavity size
- New 3cm band amplifiers currently being assembled, tested and installed by Narrabri staff

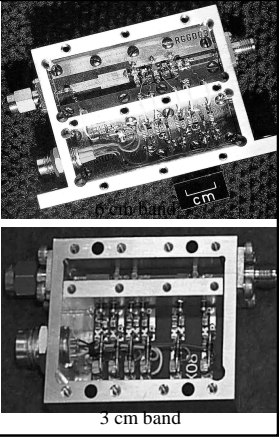

3 cm band

**Receiver:**  
20/13 cm band

- Polariser
- 70 Kelvin radiation shield
- Dewar - upper section
- Cryogenic refrigerator



**Receiver:**  
20/13 cm band  
(First Prototype)

- Polariser
- Band select switches (now replaced with bandsplitters)
- Low-noise amplifiers
- 20 Kelvin cold plate
- 70 Kelvin radiation shield

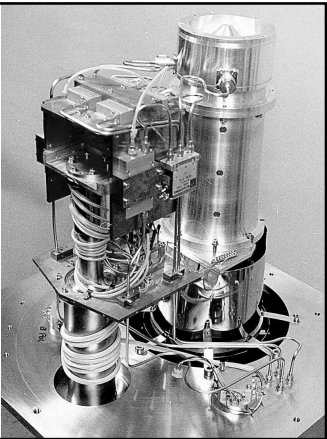

**Compact Array  
Zenith System Temperature**

	Noise temperature contribution (Kelvin)			
	1472 MHz	2308 MHz	4780 MHz	8360 MHz
Background	2.8	2.8	2.8	2.8
Antenna	6.0	6.0	6.5	7.0
Atmosphere	2.2	2.4	2.7	3.2
Horn + Coupler	3.0	3.0	3.0	3.0
Polarizer	3.0	3.0	3.3	3.5
Band splitter	1.0	1.0	1.8	2.0
Cables	3.5	3.5	1.0	2.8
Amplifier	8.0	10.0	14.0	16.0
2nd stage	1.0	1.0	1.0	1.0
<b>Total</b>	<b>31</b>	<b>33</b>	<b>36</b>	<b>41</b>

## Compact Array Conversion System

- C/X section
  - Input selection switch
  - First conversion
  - 20 cm or 13 cm band first IF
- L/S section
  - Input selection switch
  - Second conversion
- Image filter select
- Sampler bandwidth select

Diagram reference: p. 155

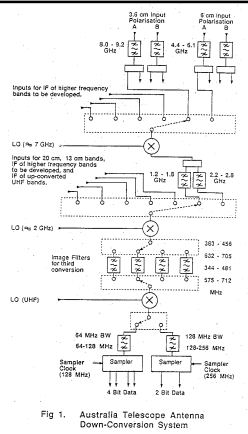

## Compact Array Conversion System

- C22-C25: Splitter modules
- C30: Conversion module
- C40: 64/128 MHz IF module
- C53: Narrow Band Filter module

Diagram reference: p. 154

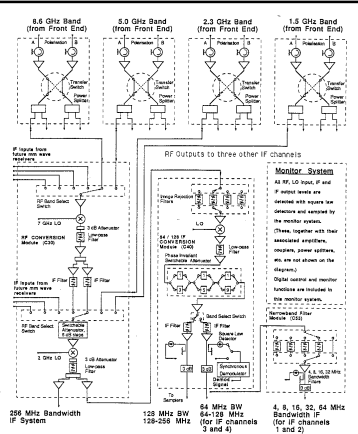

## Compact Array Antenna Vertex Room

- Local Oscillator rack on left
- Sampler rack on right

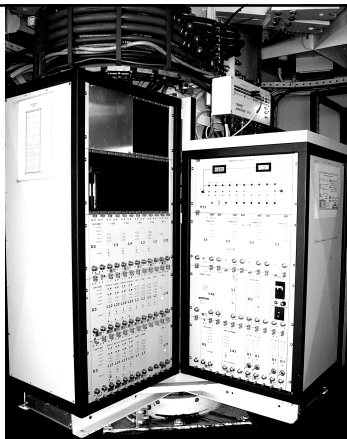

## Compact Array mm-Wave Extension

Molecular Lines of Interest to Astronomers

Molecule	Frequency (GHz)	Line Frequencies (GHz)
CO	115	115.7, 115.7, 115.7
CO	115	115.7, 115.7, 115.7
CO	115	115.7, 115.7, 115.7
CO	115	115.7, 115.7, 115.7
CO	115	115.7, 115.7, 115.7
CO	115	115.7, 115.7, 115.7
CO	115	115.7, 115.7, 115.7
CO	115	115.7, 115.7, 115.7
CO	115	115.7, 115.7, 115.7
CO	115	115.7, 115.7, 115.7

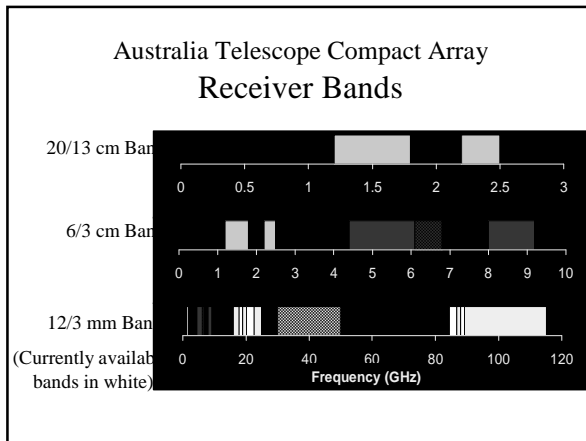

### Compact Array mm-Wave Extension

- Three new bands:  
 3 mm band (85-115 GHz)  
 7 mm band (30-50 GHz)  
 12 mm band (16-25 GHz)
- In a common cryogenic package
- Use Indium Phosphide monolithic microwave integrated circuits for the low-noise amplifiers, mixers, frequency doublers ...

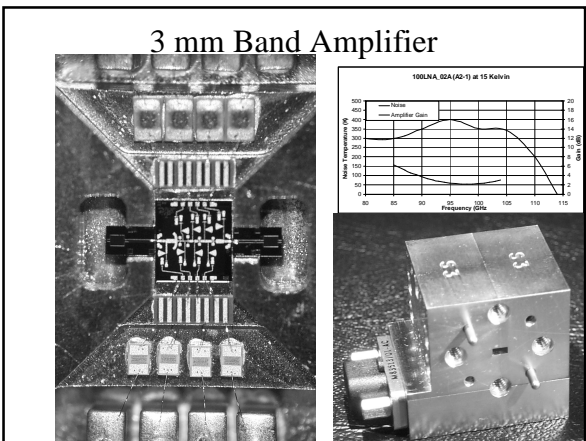
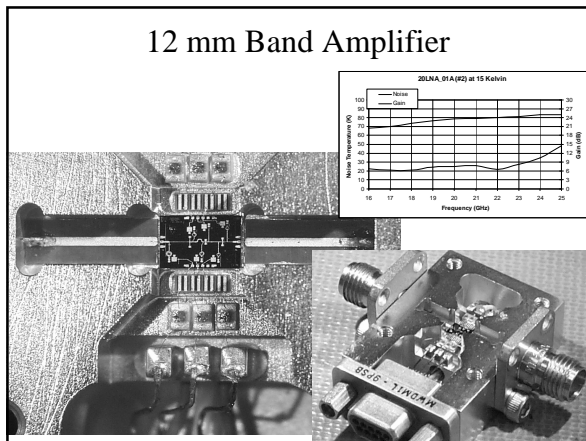

### 3mm Receiver Performance Predicted and Measured

