

Radio telescopes of the world, 2009.

John Storey
UNSW

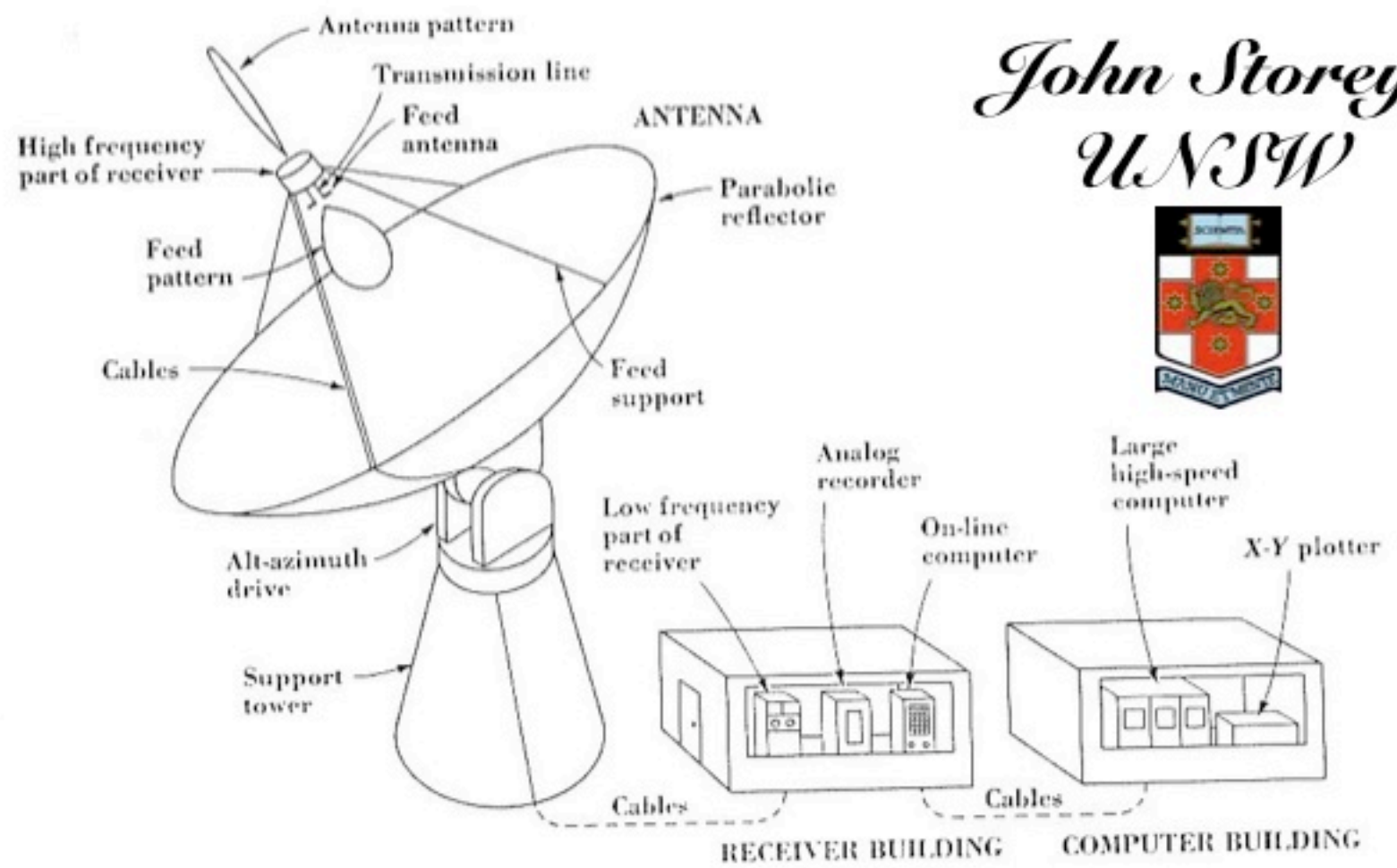

Fig. 1-6. A modern radio telescope.

Outline

- Dipoles and quarter waves
- Low-frequency antennas
- Horn antennas
- Dish antennas
 - Surface accuracy
 - Off-axis antennas
- Interferometers

Outline

- **Dipoles and quarter waves**
- Low-frequency antennas
- Horn antennas
- Dish antennas
 - Surface accuracy
 - Off-axis antennas
- Interferometers

The half-wave dipole antenna

The basic radio antenna is a half-wave dipole. The electromagnetic wave sets up a standing wave of voltage and current along the antenna in manner analogous to a vibrating string or an organ pipe.

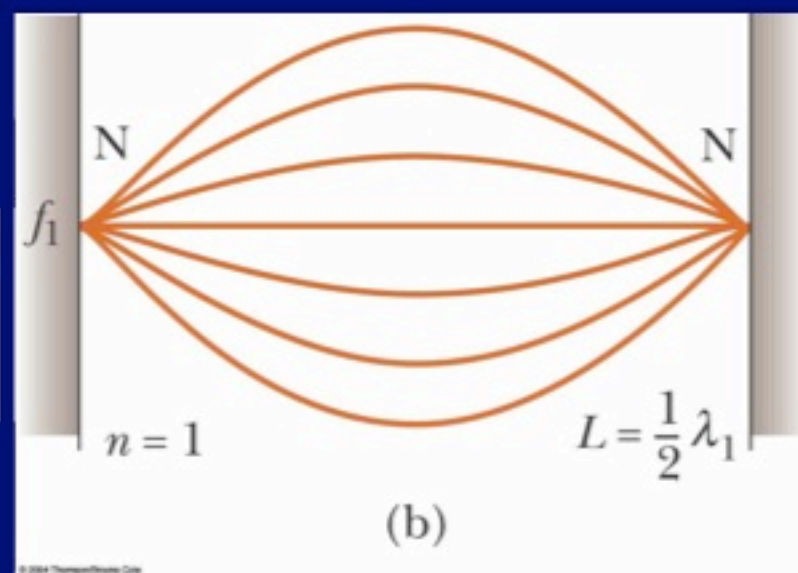
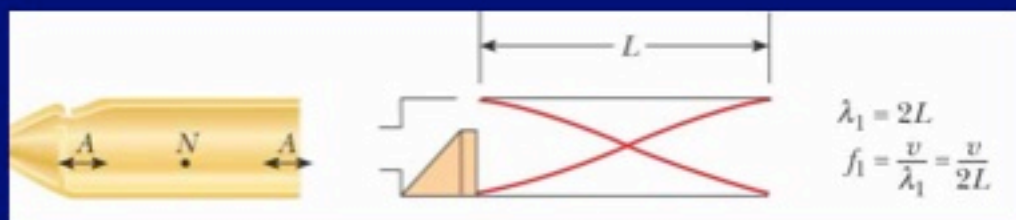

Antenna pattern

A dipole antenna does not respond equally to radiation that is incident from all directions. A plot of response as a function of direction is called the antenna pattern. In the case of the dipole, it is a donut shape, with maximum response perpendicular to the axis of the antenna.

Note also that the antenna responds to only a single polarisation. We can add a second, orthogonal, dipole if we like.

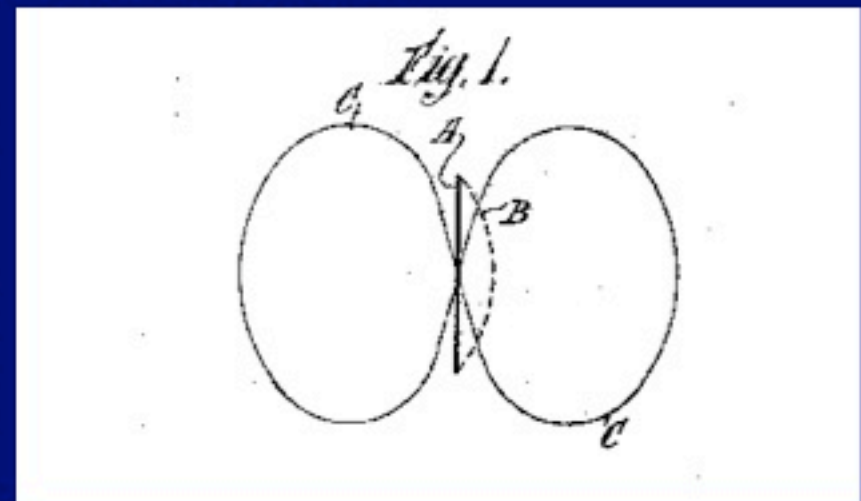

Beyond the antenna

From this point on, we are dealing with an electrical signal, which we can process in various ways with diverse pieces of electronic wizardry.

This is very different to optical astronomy, where most of the signal processing (spectral analysis, beamshape definition...) is done *before* the photons are converted to an electrical signal.

Bandwidth

A resonant antenna of any kind has a limited bandwidth. Various tricks are used to increase the bandwidth of dipole antennas, including using “fat” antenna elements.

Here is a “bow-tie” TV antenna. The loop can also increase the electrical impedance, which helps to make the receiver engineers happy.

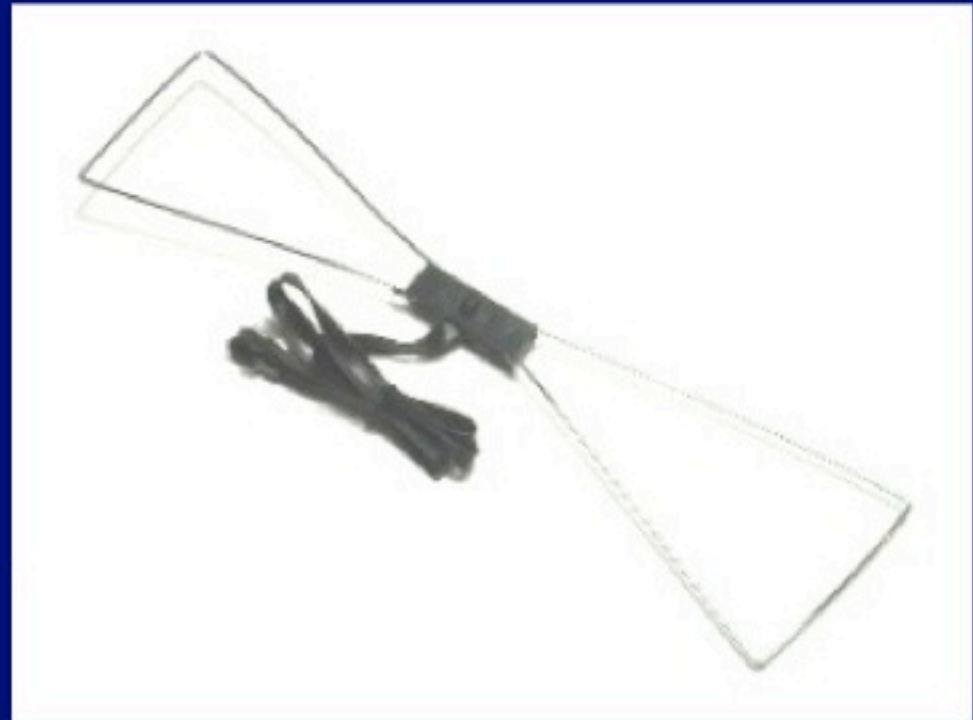

Crossed bowtie

Broadband, dual polarisation antenna for the Murchison Wide-field Array (MWA).

Happy astronomers,
happy engineers.

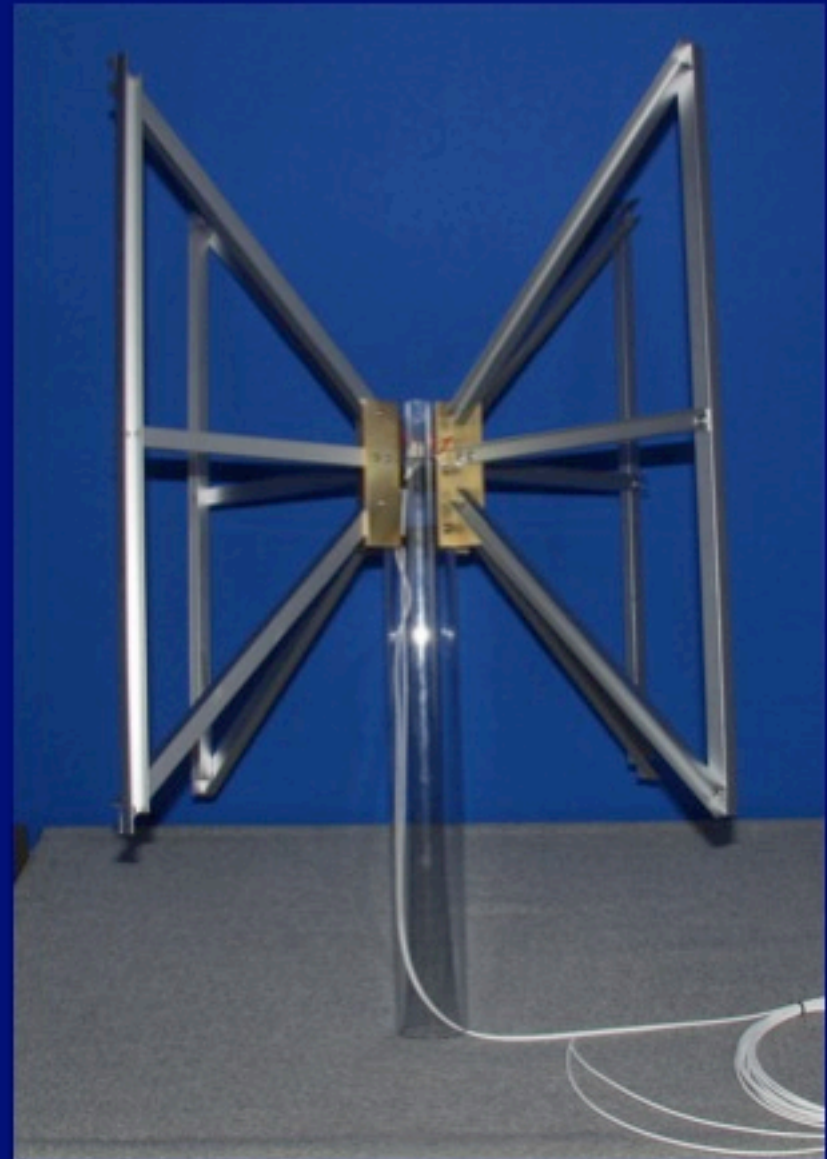

The bow-tie or “butterfly” antenna

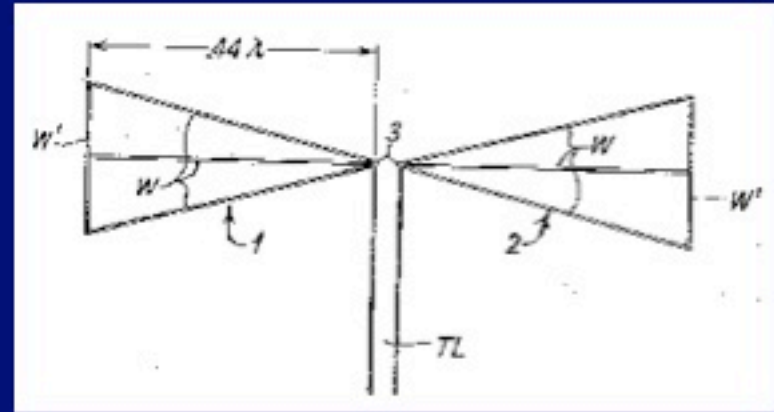

- US Patent Number: 2175253
- Year:1938
- Inventor: Philip S. Carter
- Excerpt: The present invention relates to a short wave antenna system and has for one of its objects to provide a simple form of short wave antenna which has an impedance versus frequency characteristic considerably wider than that of a simple dipole type of antenna.

Quarter-wave antennas

We can chop a dipole in half and replace the missing piece with a reflecting screen. The remaining piece is $\lambda/4$ long.

The reflecting screen might be the ground, a few strategically placed wires, or – in the case of a mobile phone – your head.

A quarter-wave antenna is a little like a closed organ pipe.

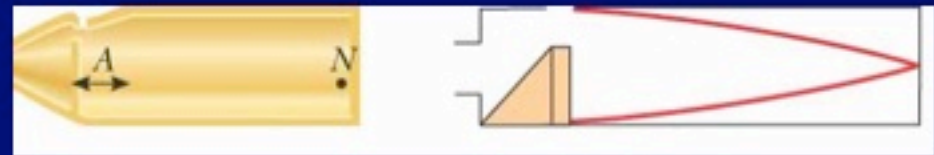

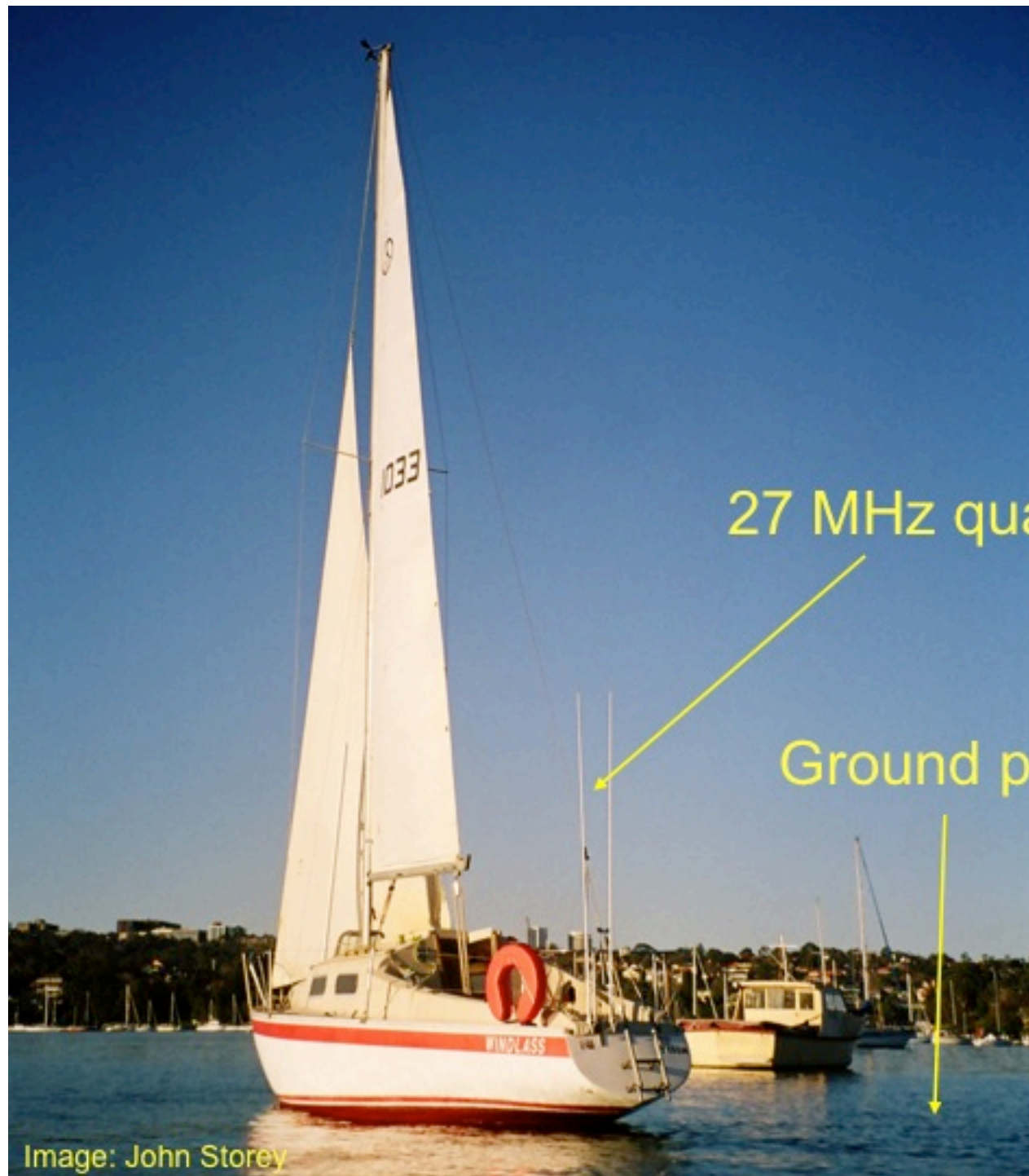

27 MHz quarter-wave antenna

Ground plane (wet and salty)

Image: John Storey

AM broadcasting quarter-wave antenna



In a radio telescope, the last thing a photon sees before it becomes a bunch of electrons is usually a half-wave or quarter-wave antenna.

Antenna gain

Every antenna can be characterised by gain, directivity, beamwidth etc .

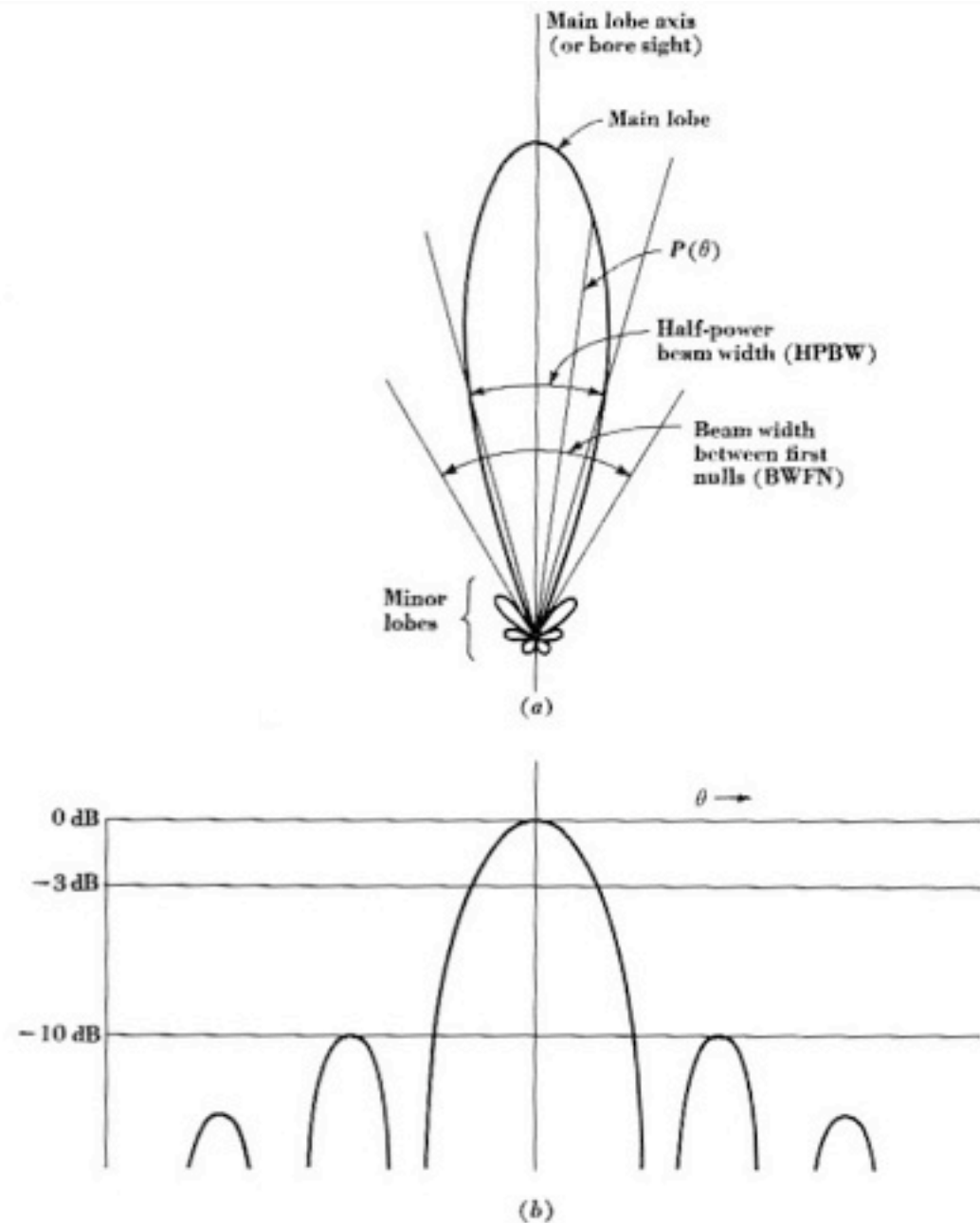

Fig. 6-1. (a) Antenna pattern in polar coordinates and linear power scale; (b) antenna pattern in rectangular coordinates and decibel power scale.

Outline

- Dipoles and quarter waves
- **Low-frequency antennas**
- Horn antennas
- Dish antennas
 - Surface accuracy
 - Off-axis antennas
- Interferometers

The Franklin antenna

British Patent Number: 242342

Year: 1924

Inventor: Charles Samuel
Franklin

Abstract: In order to secure a pronounced directional effect from aerials of the type that are electrically long in comparison with the signal wavelength, provision is made for suppressing radiation from every alternate half wavelength of the stationary-wave formation along the aerial.

From: Notable Patents on Antenna Design, Richard Kuehne

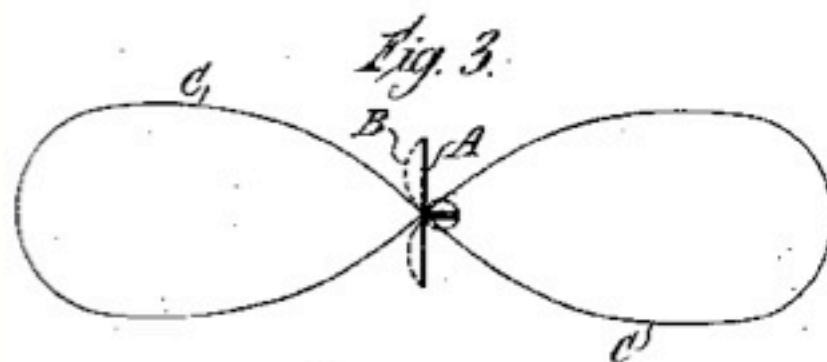
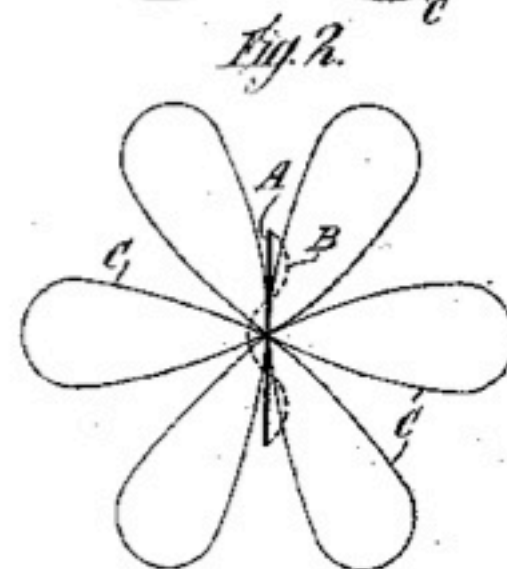
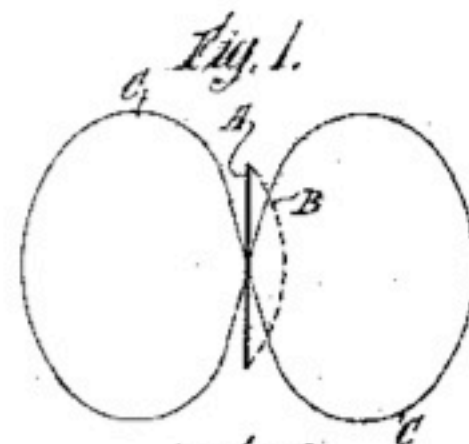

The Bruce array I

- US Patent Number: 1813143
- Year: 1927
- Inventor: Edmond Bruce
- Excerpt: Because of the physical dimensions of the antenna, energy supplied thereto by a local source for radiation, or derived from a wave incident thereupon, produces in the active elements currents which are in phase with each other.

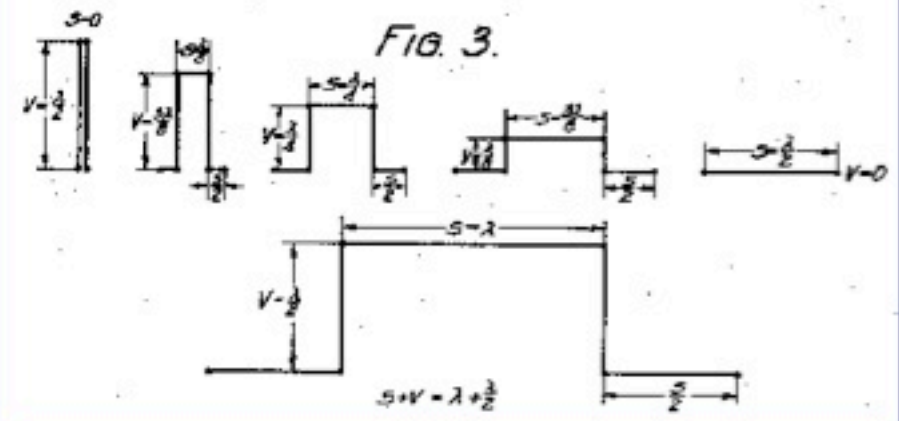
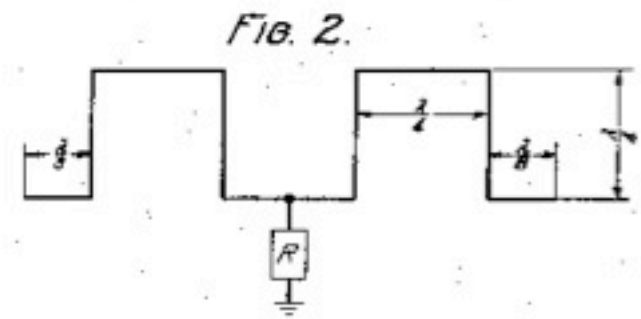
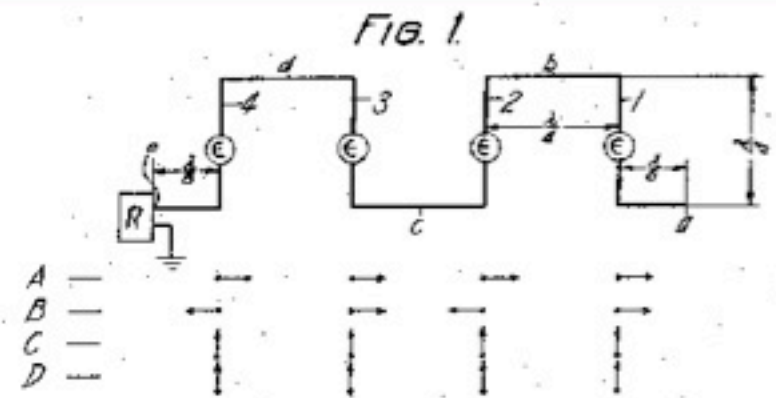

The Bruce array II

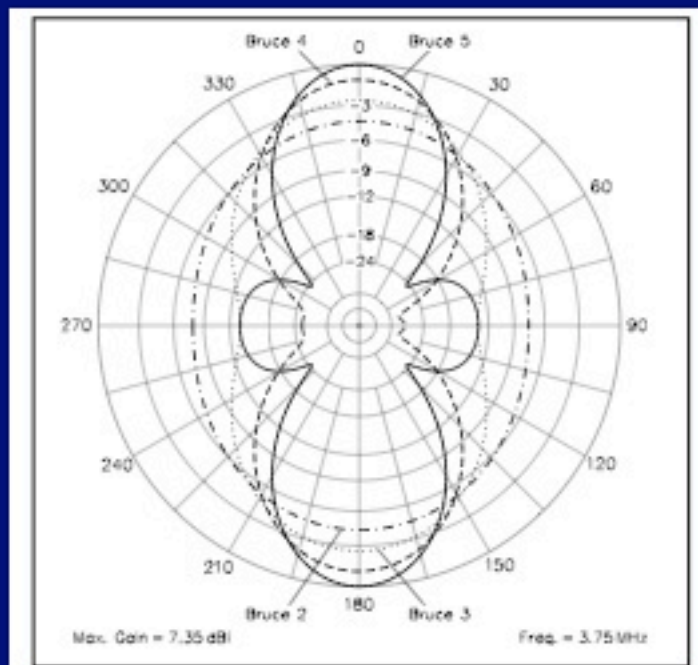

Figure 2—Comparison of free-space radiation patterns for 2 through 5 elements.

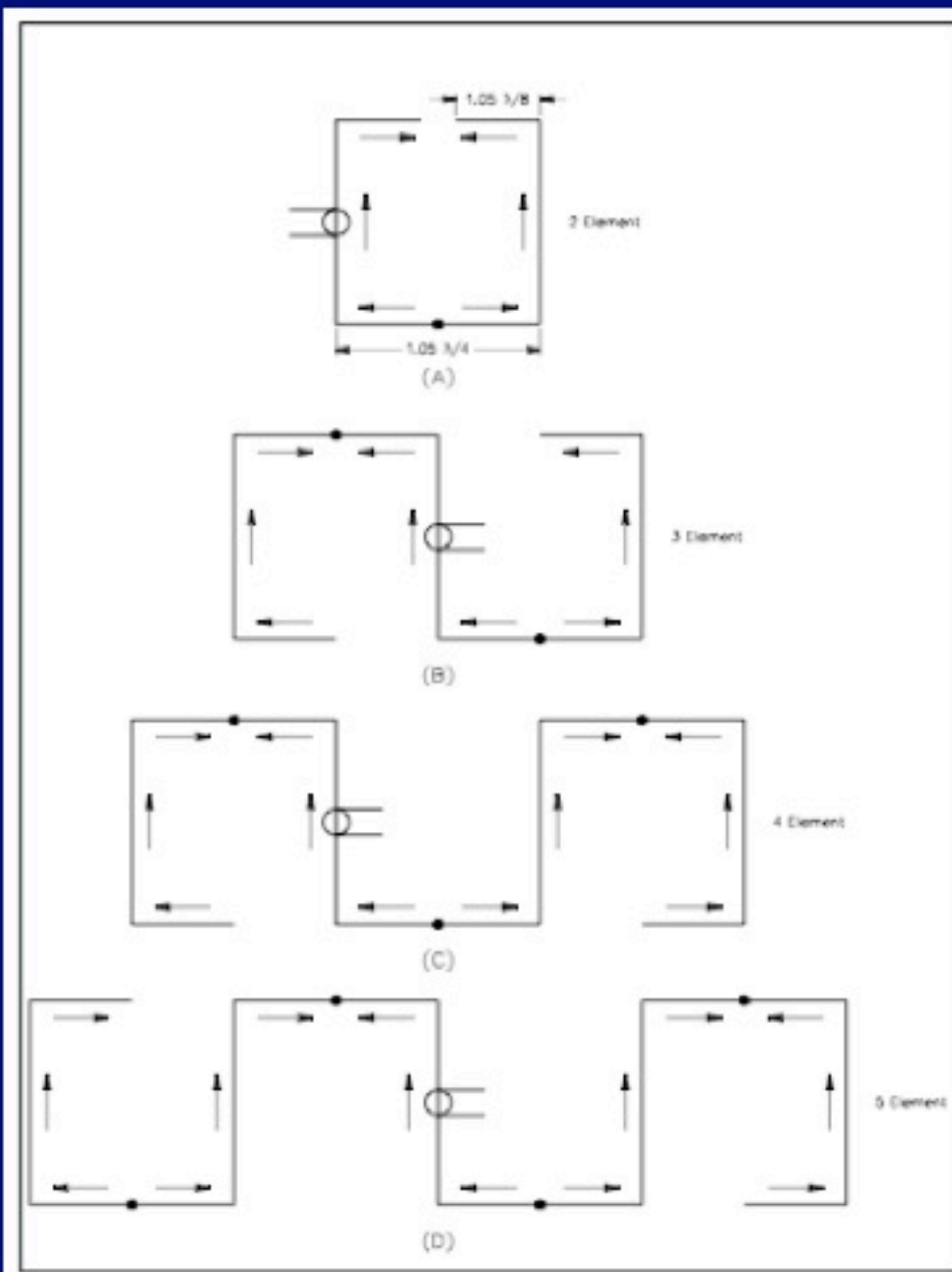
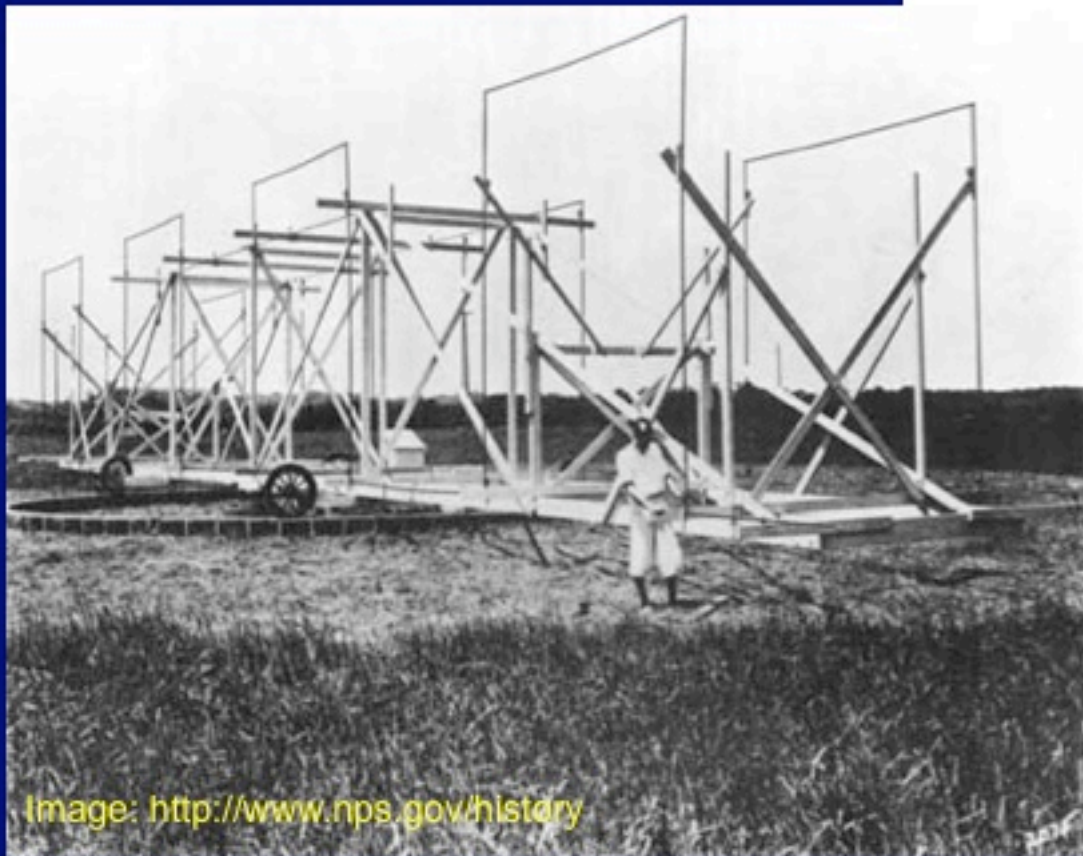
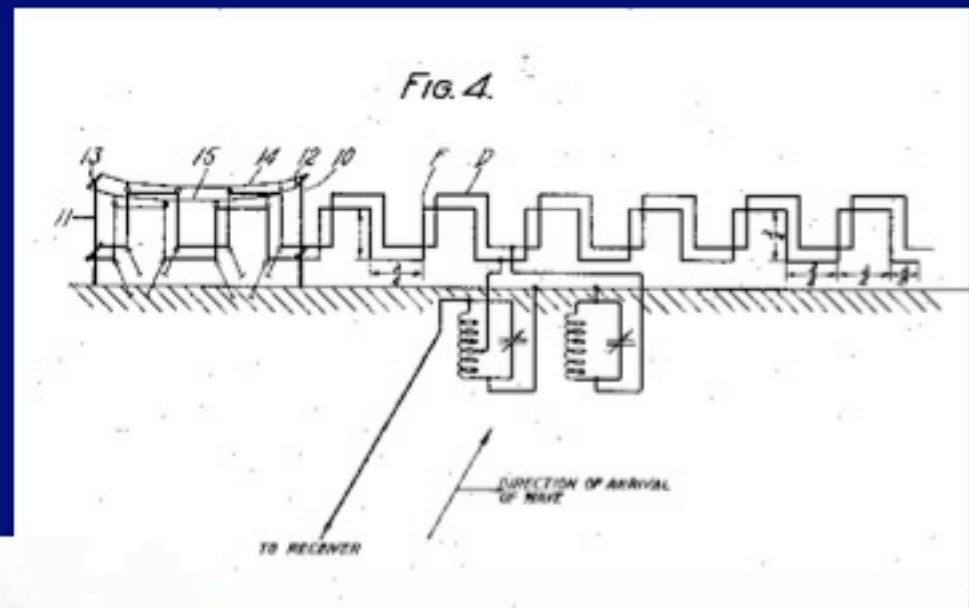

Figure 1—Bruce arrays with 2 to 5 elements. The feed points are nominal. See the text for other feed arrangements.

The Bruce array III



By adding a reflector array, $\lambda/4$ behind the first array, we can make ensure that the antenna only responds to signals from one direction.

Phased arrays

By placing several dipoles at appropriate spacings, and coupling the signals from them with appropriate phase delays, an antenna can be created that is even more directional – ie the antenna response is peaked in one direction.

This increase in response is called the *antenna gain*.

Log-periodic antennas

An often-used example of the technique of combining several dipoles is the *log-periodic* antenna, where an array of dipoles is connected along a boom.

The length of the dipoles increases along the boom: this allows the log-periodic antenna to have a much wider bandwidth.

This is a log-periodic farm in northern China.



Image: John Storey

The antennas are grown from seedlings. Once they reach maturity, they are harvested and exported all around the world.



Image: John Storey

Yagi-Uda antennas

It turns out not to be necessary to have an electrical connection to all the elements of an antenna. We can take the signal from one dipole. The other dipoles are parasitic elements; the currents that flow in these elements modify the radiation pattern of the antenna in the desired way.



Image: John Storey

The Yagi-Uda antenna

- Japanese Patent Number:
69115
- Year: 1926
- Inventors: Hidetsugu Yagi
and Shintaro Uda

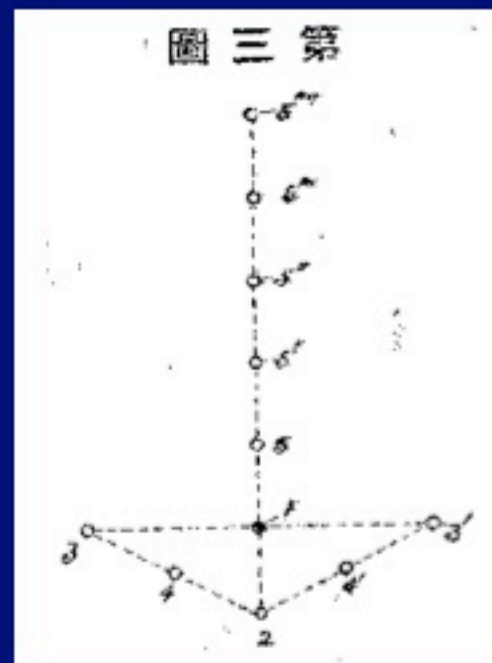

The corner reflector antenna

- US Patent Number: 2270314
- Year: 1940
- Inventor: John D. Kraus

From: Notable Patents on Antenna Design,
Richard Kuehne

Filed Jan. 31, 1940

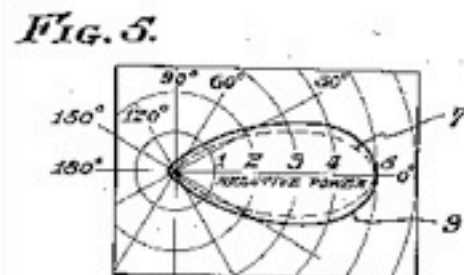
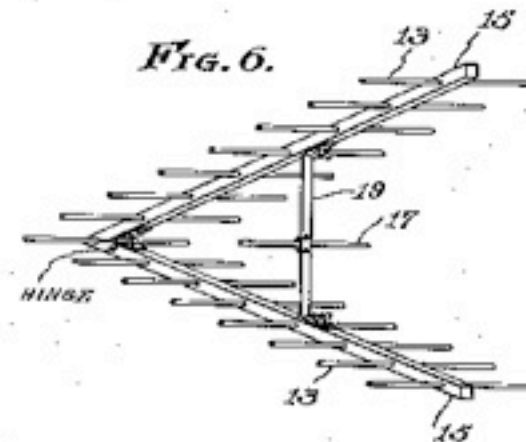
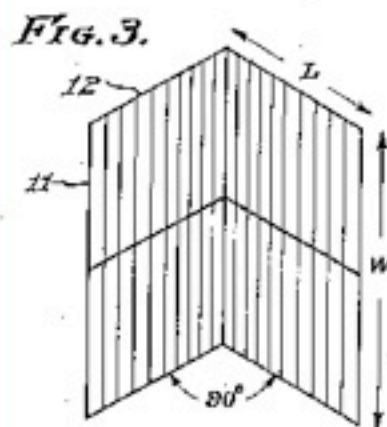
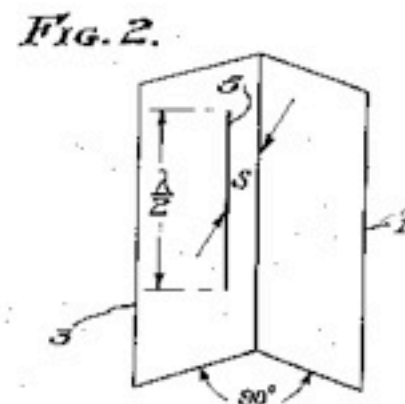
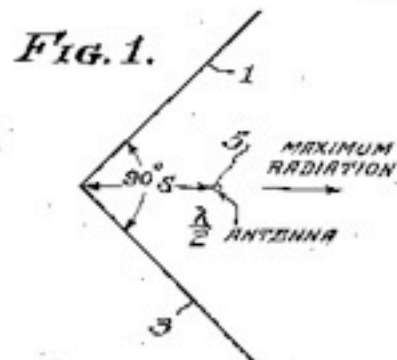

Inventor
John D. Kraus.
John D. Kraus
Attorney



Image: John Storey

Four yagi antennas looking *down*, as part of an ice radar.



Image: LI Yuansheng

Antenna arrays

A reasonable approach to building a radio telescope would be to bolt a large number of yagis or log-periodic antennas together and wave them around the sky.

The individual antennas need to be spaced by of order λ , and so such an antenna rapidly becomes quite cumbersome.



1952

Images: CSIRO ATNF

Antenna arrays - II

With modern digital electronics, it is no longer necessary to wave the antennas around.

The individual antennas are designed to have a response pattern or *primary beam* that covers as much of the sky as is of interest.

Varying the delays between the signals collected at each antenna before they are combined enables the synthesised high-gain beam to be steered around the sky (within the limits imposed by the primary beam).

Antenna arrays - III



We'll call this an *interferometer*. This one is Sydney University's Molonglo Observatory Synthesis Telescope.

Antenna arrays - IV

With modern digital electronics, plus extreme cleverness, there is no need to be restricted to a single synthesised beam. You can have as many such beams as you wish.

One might therefore propose an array of relatively low-gain individual antennas, whose primary beams cover a substantial fraction of the sky.



An antenna farm in Western Australia before the antenna seedlings have been planted.

Image: John Storey

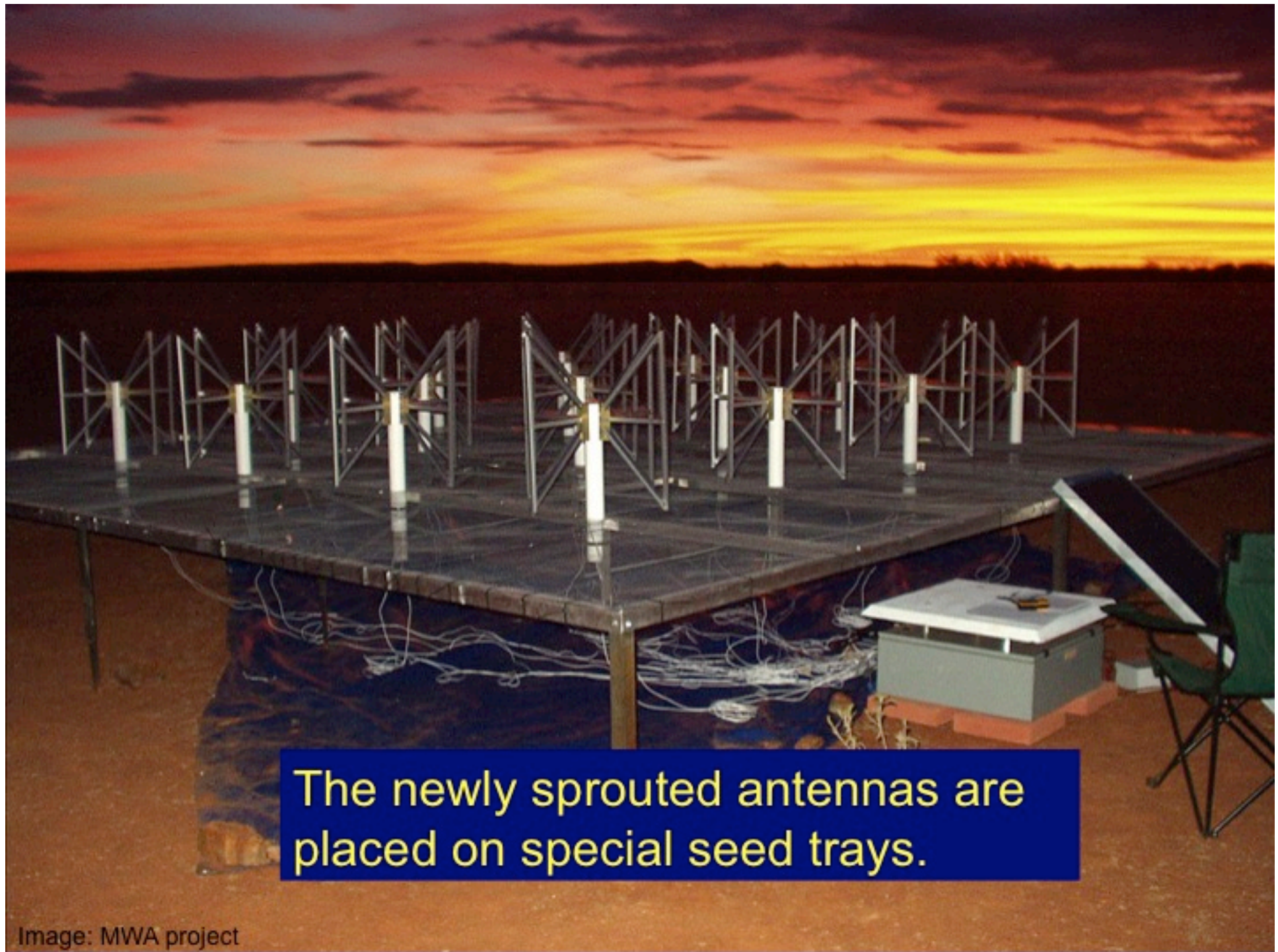

The newly sprouted antennas are placed on special seed trays.

Image: MWA project



When they are fully grown, they are harvested to provide antennas for satellite TV.

Outline

- Dipoles and quarter waves
- Low-frequency antennas
- **Horn antennas**
- Dish antennas
 - Surface accuracy
 - Off-axis antennas
- Interferometers

The horn antenna

The gain, antenna pattern, etc. can be calculated from first principles.

It is also easy to construct.

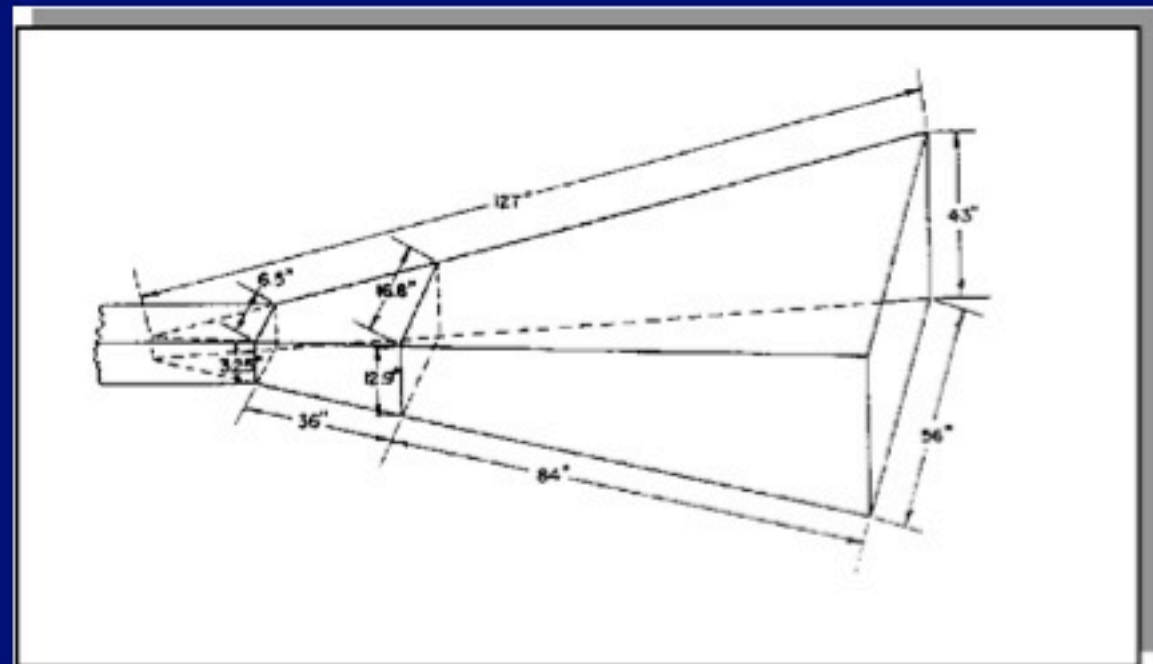

HORN ANTENNA

The design of the horn antenna was based on descriptive information presented in the Rad Lab book on Antennas by Sam Silver. The maximum size was determined by the geometric constraints of the fourth floor parapet at Lyman Lab.

I sent my calculations and sketches to Sam for a sanity check, before sending the build order to the Physics Dept. Model Shop. It was up on the parapet in about three weeks.

These folk are planning to make one...

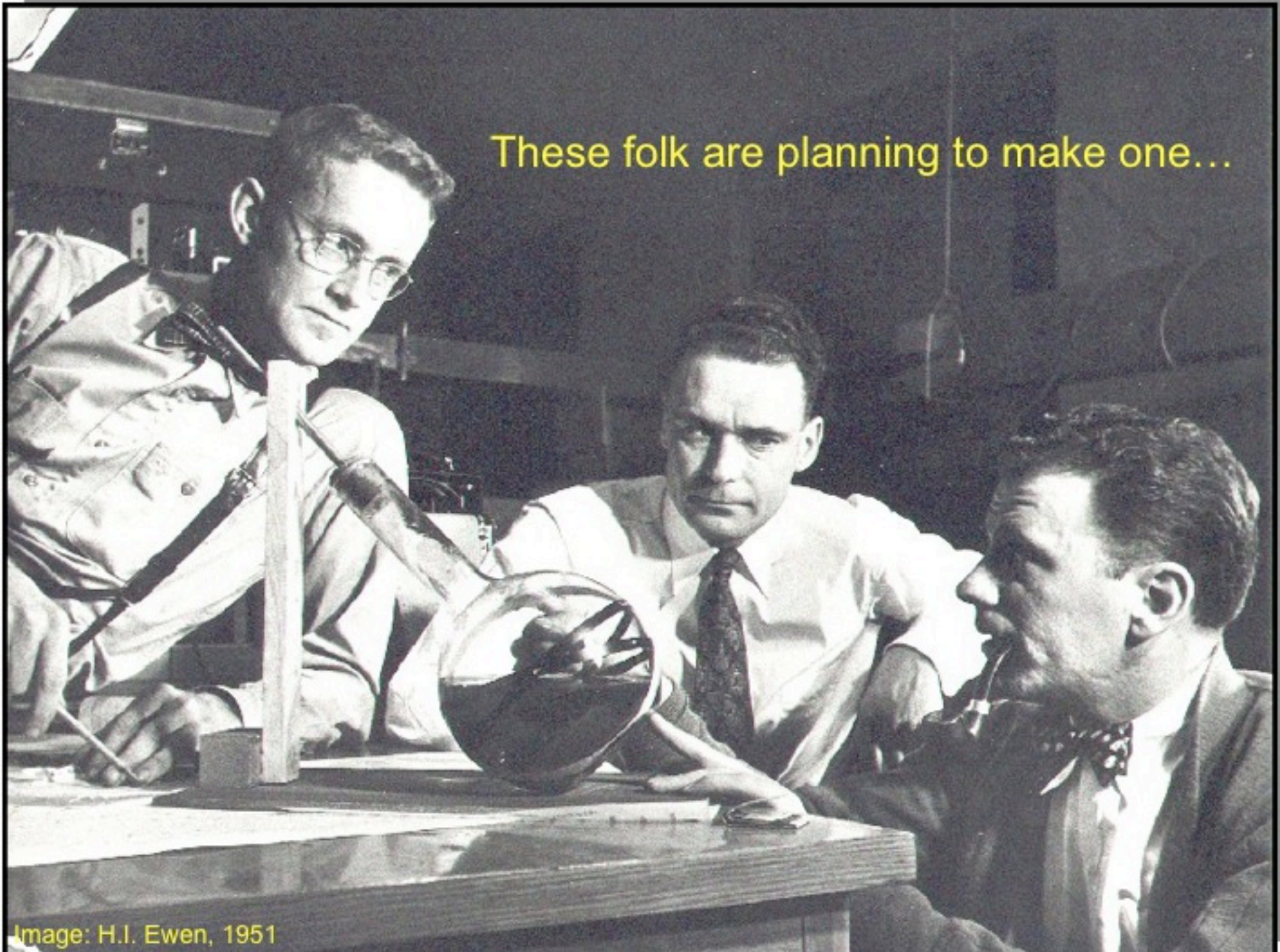

Image: H.I. Ewen, 1951

...and hook it up to a receiver they just built.

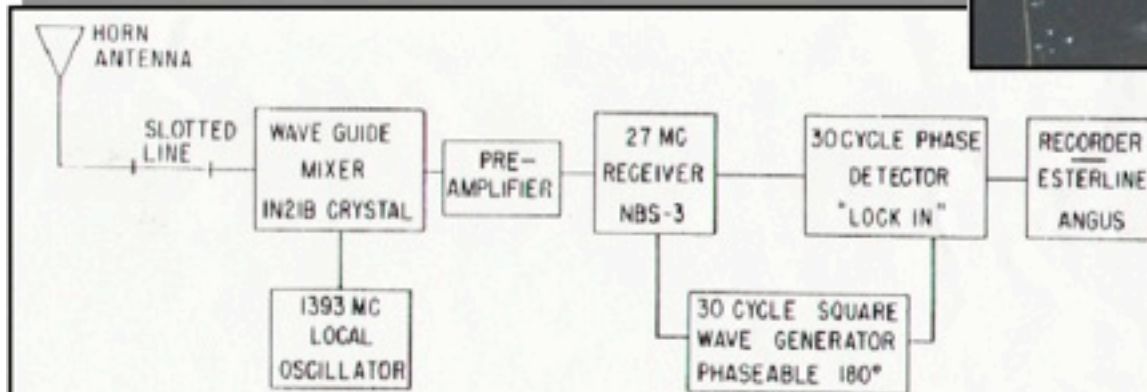

Figure 1. Block diagram of the equipment.



If they can stop
students lobbing
snowballs into
it...

Image: H.I. Ewen, 1951



Both they and the horn could end up quite famous.

These people also used a horn antenna...



cleaned up after pigeons...

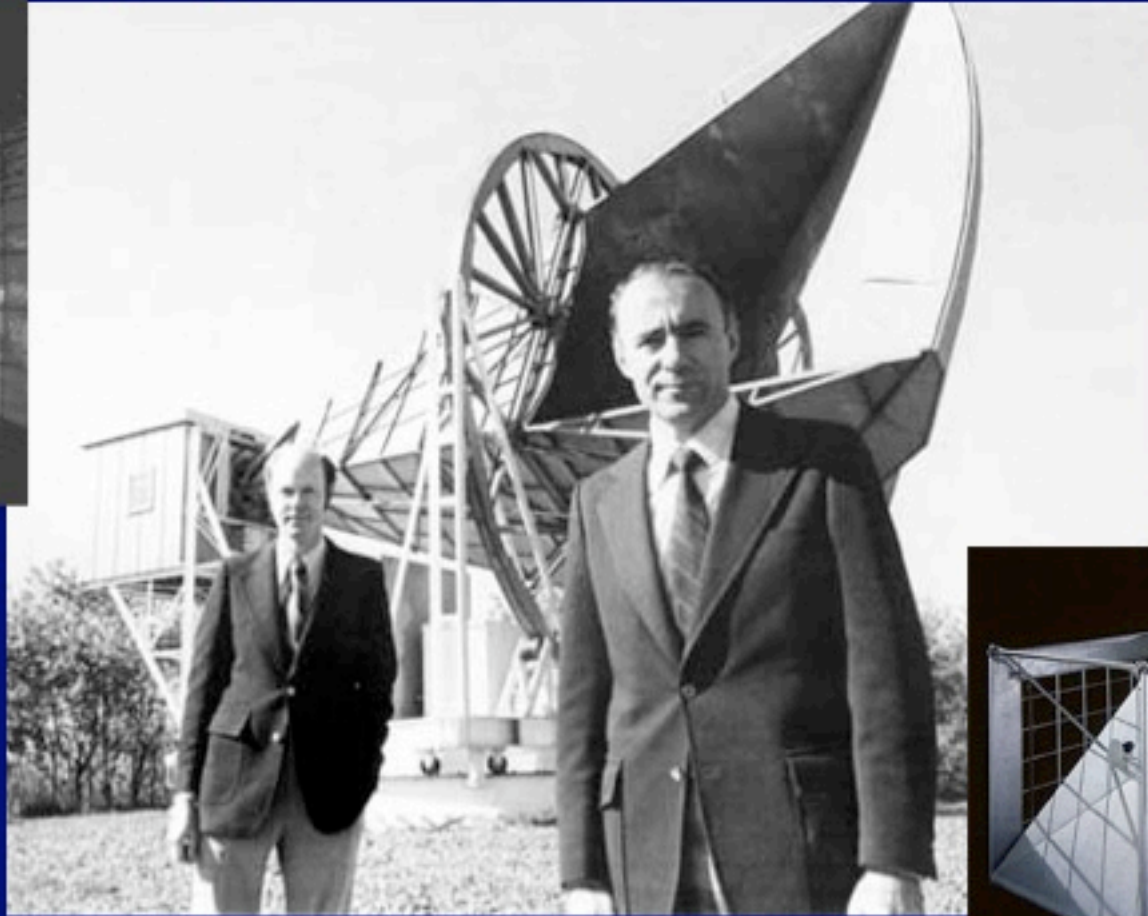

and eventually got a pigeon trap...

Images: Bell Labs
and Air & Space
Museum

...and also wound up famous.

Outline

- Dipoles and quarter waves
- Low-frequency antennas
- Horn antennas
- **Dish antennas**
 - Surface accuracy
 - Off-axis antennas
- Interferometers

Dish antennas

An alternative way to achieve high gain (or, equivalently, *high directivity* or *good spatial resolution*) is to use a parabolic dish.

At the focus of the dish is placed a “feed”, which might be a waveguide horn or even a simple dipole antenna.

Such a telescope, with a single reflector and a feed at the focus is called a *prime focus* telescope. Examples include Parkes.

The Parkes 64 m antenna.

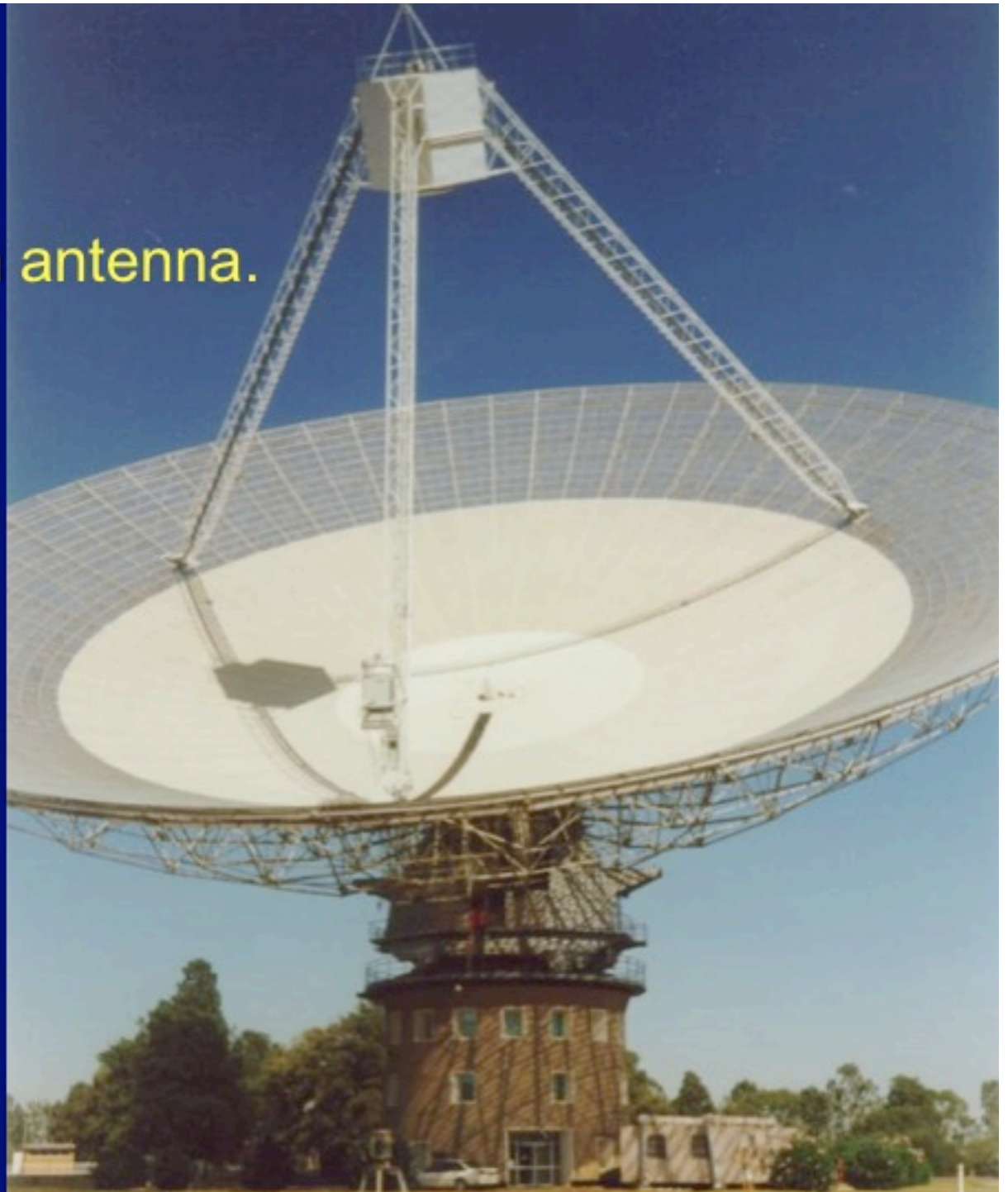
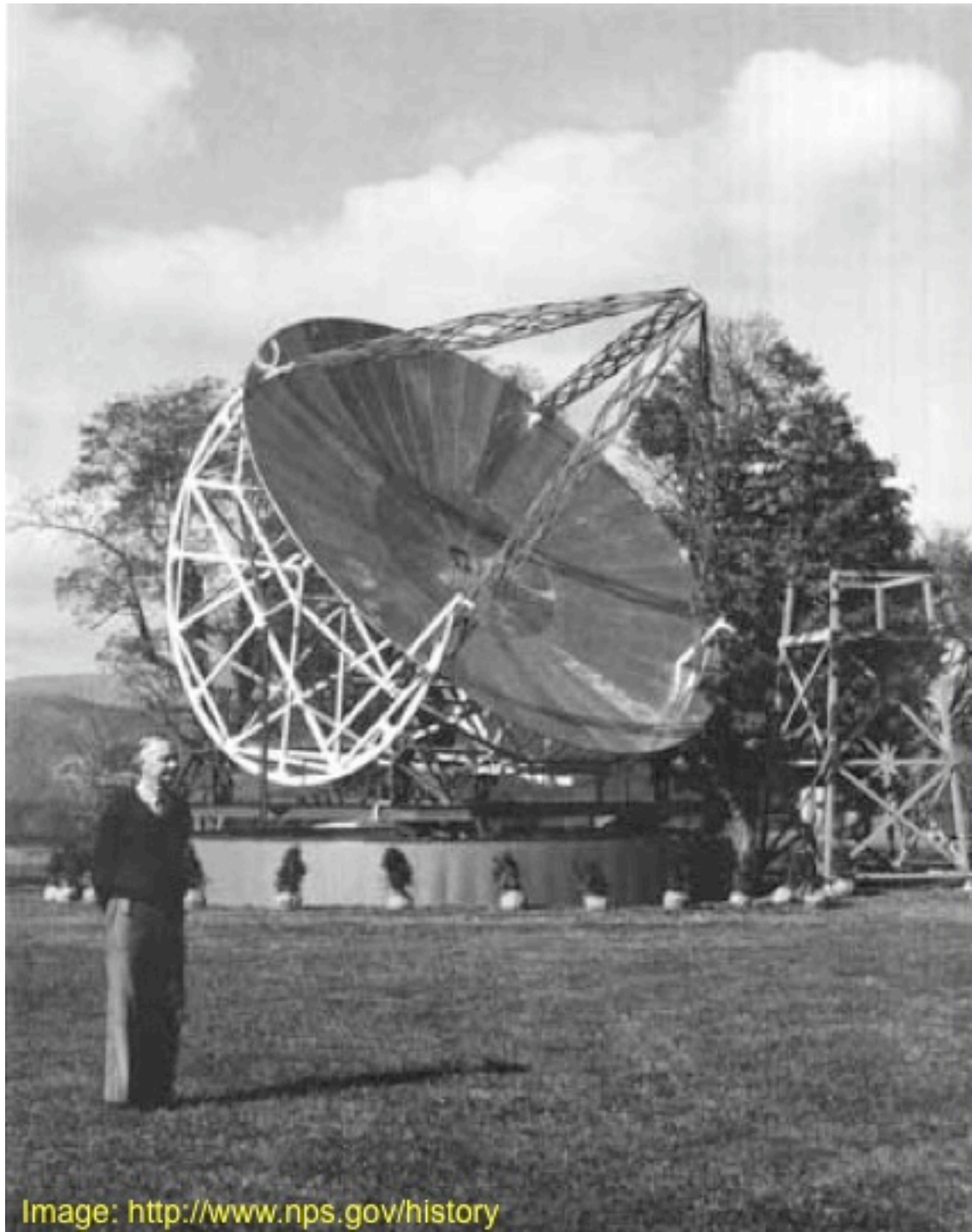

Image: CSIRO ATNF

Reber changed the face of radio astronomy

For example, he started
the disturbing tradition of
people posing
awkwardly in front of
antennas.





This tradition
continues to the
present day.

IRAM 30 m, Pico
Veleta, Spain

Urumqi 25m dish,
China

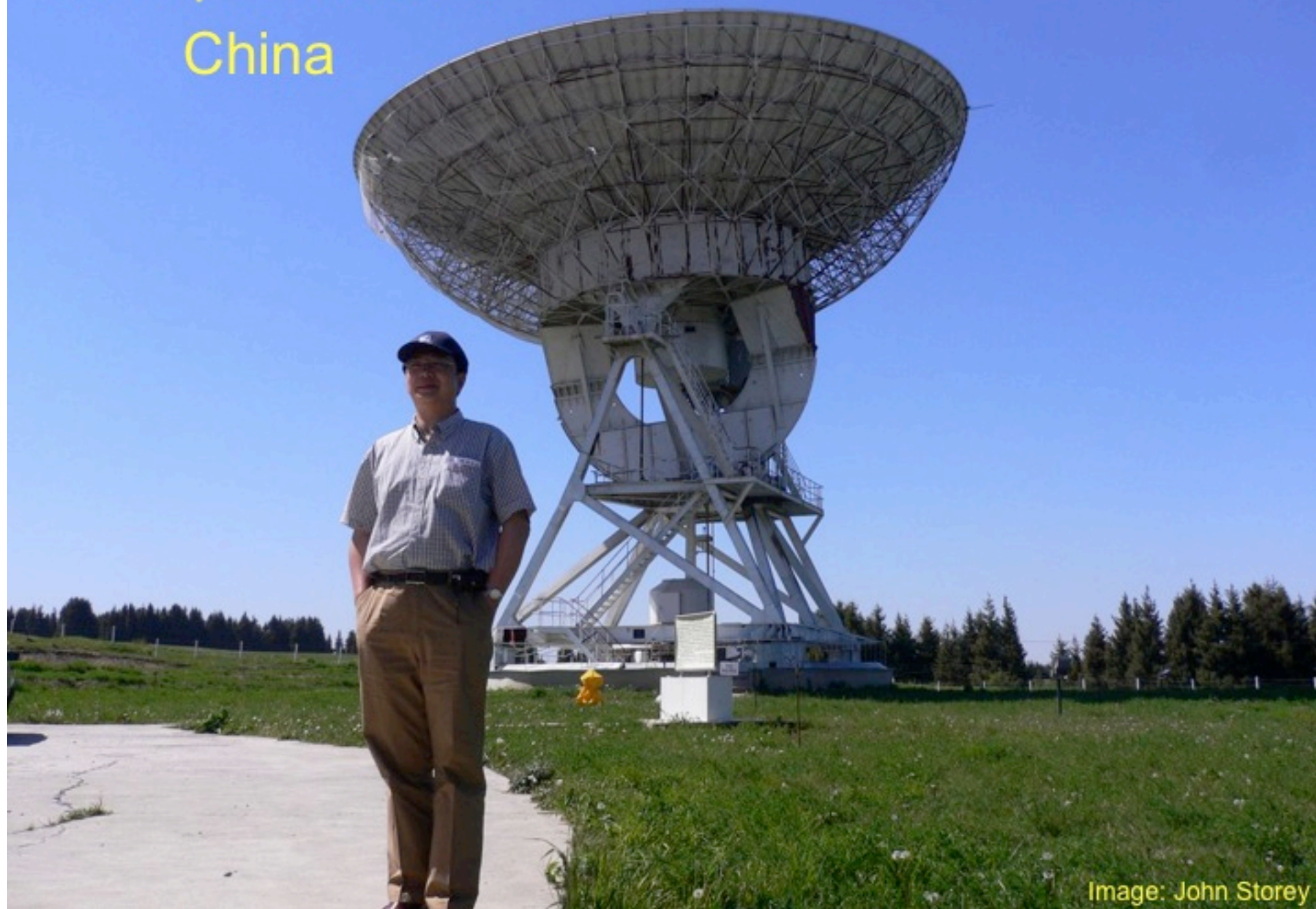

Image: John Storey

Traditionally, prime-focus antennas have required excellent soil to grow to large sizes.



Image: John Sarkissian

However, in India a strain of water-loving antennas have recently been developed, allowing them to be grown in old rice paddies.



Image: GMRT project

Cassegrain & Gregorian antennas

There are several good reasons why it might be more desirable to place a *subreflector* close to the primary focus of the dish and bring the beam down to a new focus somewhere near the vertex of the dish.

- Easier access to the receiver
- Less weight to be supported on feed legs
- Better control of aperture illumination
- Spillover sees cold sky not warm ground
- Subreflector can be made to chop to cancel sky emission

Prime focus (eg, Parkes)

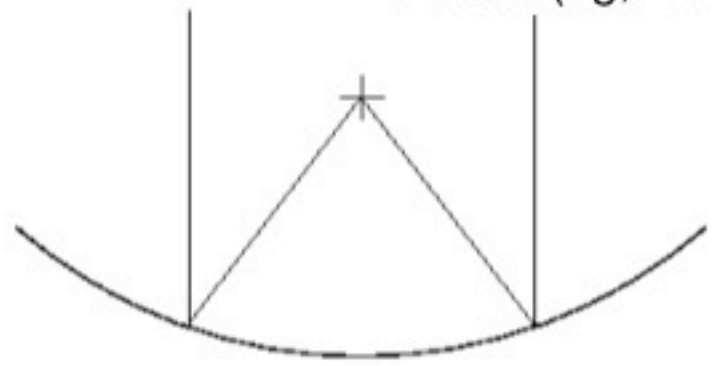

Gregorian (eg, Effelsberg)

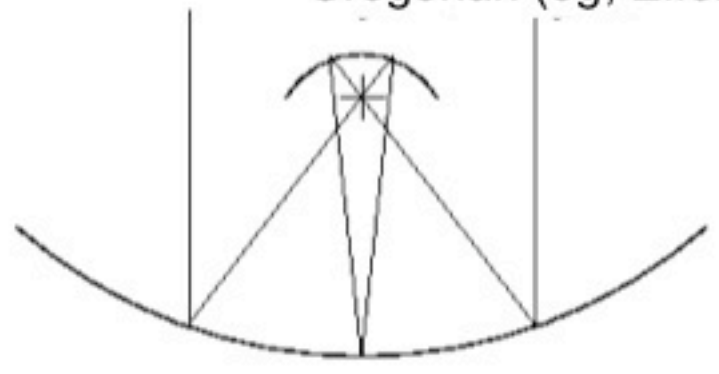

Cassegrain (eg, Kitt Peak)

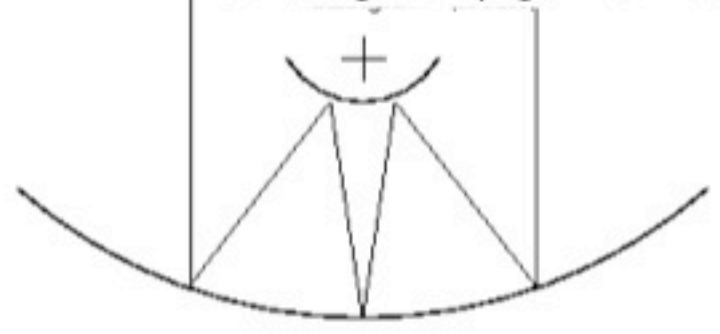



Gregorian: Effelsberg 100m, Germany

Image: MPIfR, Germany



Cassegrain: 12 metre, Kitt Peak, Arizona

Image: University of Arizona, T.W. Folkers

Nasmyth, Bent Cassegrain, and more

Once you feel comfortable using a subreflector, there is no reason not to use additional mirrors to bounce the beam around and convey it to a more convenient focus – perhaps one that remains stationary as the telescope moves around the sky.

This is normally only done at millimetre wavelengths, as each mirror has to be many wavelengths in diameter to avoid diffraction effects.

Submillimeter telescopes on Mauna Kea



Antenna pattern of a dish

Let's reverse time and imagine that the detector is a source of radiation, and that the telescope is transmitting into space. This is a common trick with both radio and optical systems, and makes things easier to visualise.

Now, our dish is illuminated by the feed (perhaps via the subreflector and other "optical" components).

The beam pattern will be determined by the distribution of intensity across the aperture, which of course is determined by the beam pattern of the feed.

Airy pattern

If we *uniformly* illuminate the dish, we end up with an Airy pattern. This is the usual situation with an optical or infrared telescope.

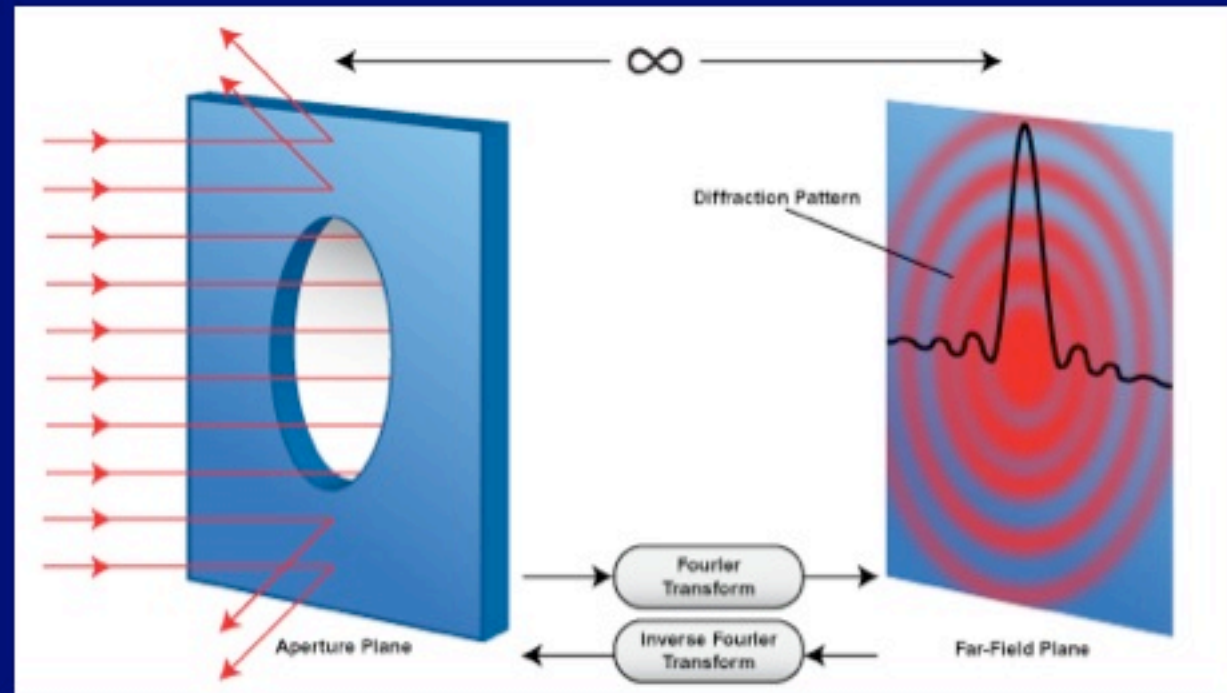

The FWHM of the beam is $\sim \lambda/D$, and the diameter of the first "null" is $2.44 \lambda/D$. The secondary Airy rings are called *sidelobes*.

Seeing

In real life, the resolution of a telescope in the optical or near infrared is limited by atmospheric turbulence, or *seeing*, to a value of 0.5 ~ 2 arcseconds, and we don't get to see the Airy rings.

With *adaptive optics* (preferably at an Antarctic site), the potential exists to greatly reduce the effects of the atmosphere and recover something close to the diffraction limit.

Meanwhile, seeing is rarely of any significance to single-dish radio astronomy.

Aperture illumination - I

At radio wavelengths, the feed will naturally produce an illumination of the dish that varies from a maximum at the centre to a smaller value at the edges. This is known as *taper*.

Too much taper and the edges of the dish are barely being used, and so the effective collecting area is being reduced.

Too little taper and there will be a lot of *spillover* – in other words the feed sees the ground (or the sky) instead of the dish. Also, the level of the *sidelobes* will increase.

Aperture illumination - II

The antenna pattern is the Fourier transform of the aperture distribution.

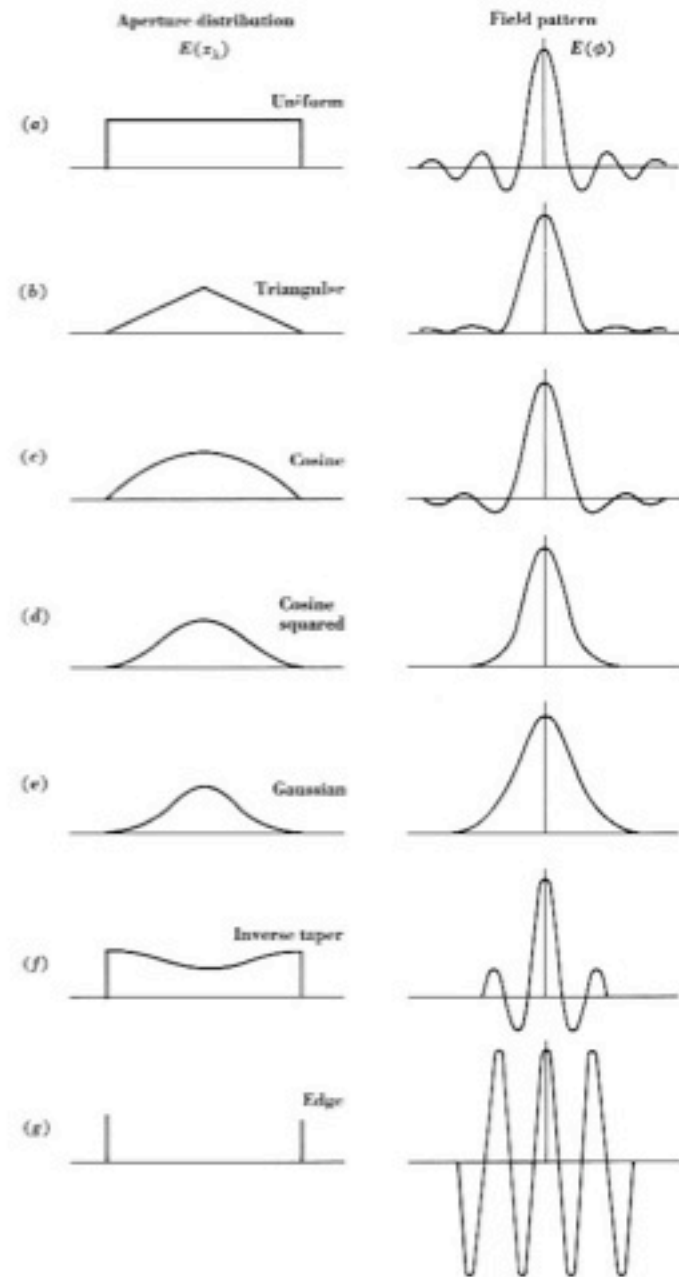

Fig. 6-9. Different aperture distributions with associated antenna patterns.

Aperture illumination - III

There is a direct trade-off between aperture efficiency (extent to which full aperture is used) and beam efficiency (fraction of response that is *not* in the sidelobes).

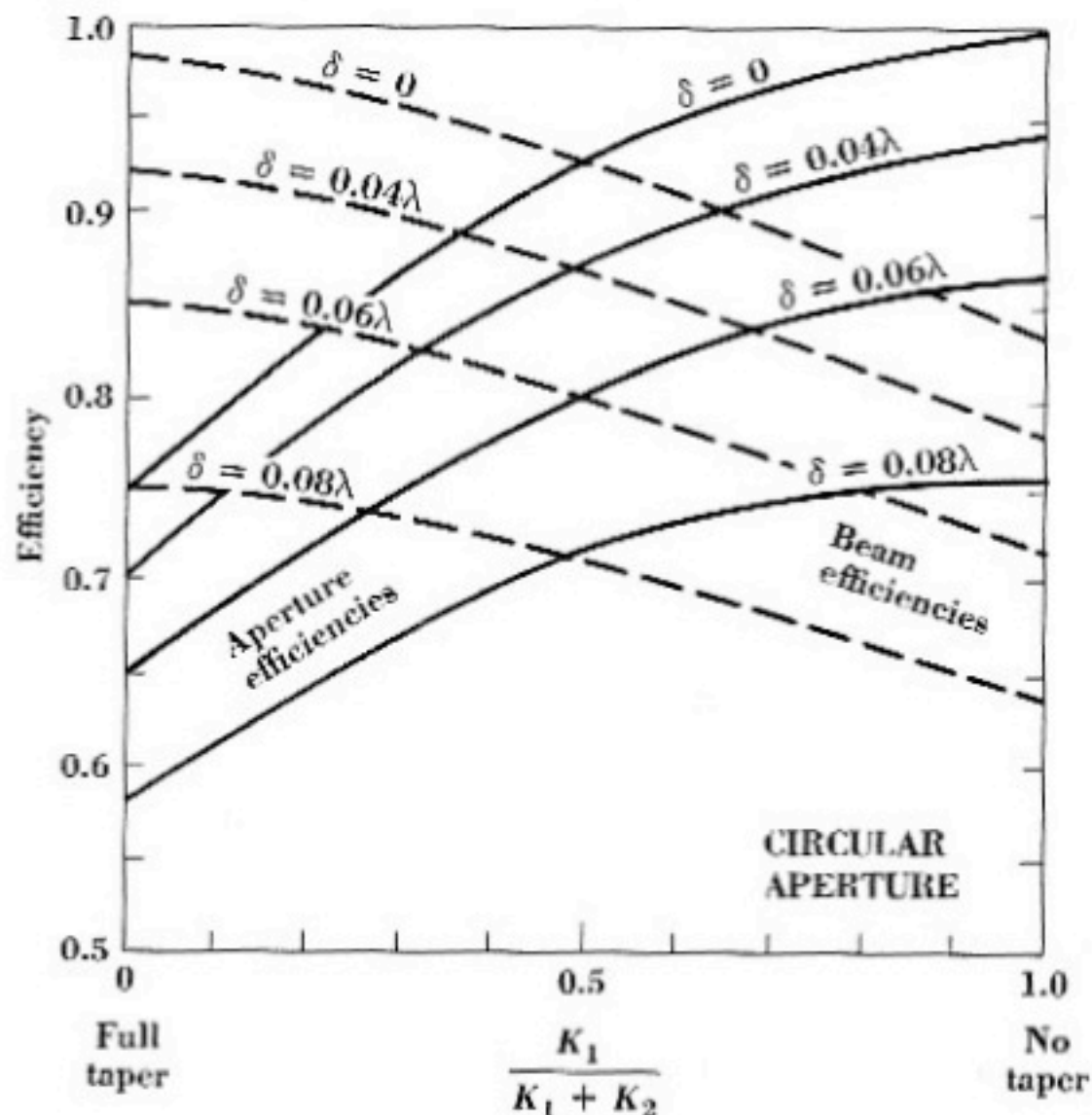

Fig. 6-61. Aperture efficiency (solid) and beam efficiency (dashed) of a circular aperture as a function of taper and phase error. (After Nash, 1964.)

Apodisation

In an optical telescope, the detector naturally produces an essentially uniform illumination of the primary mirror.

However when diffraction-limited imaging is being achieved by whatever means, it may be desirable to reduce the intensity of the Airy rings (“sidelobes”) by “tapering” the aperture illumination. This is usually done with an apodising mask, whose transmission decreases towards the edges.

Such a mask throws away a lot of light.

Extra-solar planets

The possibility of directly imaging extra-solar planets in the near-infrared is driving intense research into improved apodising masks.

A recent proposal is *Phase Induced Amplitude Apodisation* (PIAA) which redistributes the light across the telescope pupil in a very similar way (though for different reasons) to the “shaped” sub-reflectors and dishes of the AT.

As adaptive optics develops further, we will likely see an increasing exchange of ideas between the optical/IR and radio communities.

Outline

- Dipoles and quarter waves
- Low-frequency antennas
- Horn antennas
- **Dish antennas**
 - **Surface accuracy**
 - Off-axis antennas
- Interferometers

Surface accuracy

The surface of a telescope needs to be smooth enough to reflect the waves without introducing errors in the wavefront.

As a rule of thumb, the rms surface error, ε , should be less than around $\lambda/20$.

More precisely, the Ruze formula for the degraded efficiency, η , is:

$$\eta = \exp[(-4\pi\varepsilon/\lambda)^2]$$

Surface accuracy

So, the higher the operating frequency, the smoother the dish surface:



Mopra

Higher frequency, more
precise surface.





Even higher frequency,
even more precise surface.

Swedish-European Submm
Telescope (SEST), La Silla,
Chile

In general, a dish will work at any frequency lower than its design frequency.



Image: AAT Board

12m Atacama Pathfinder Experiment
APEX: Germany / Sweden / ESO

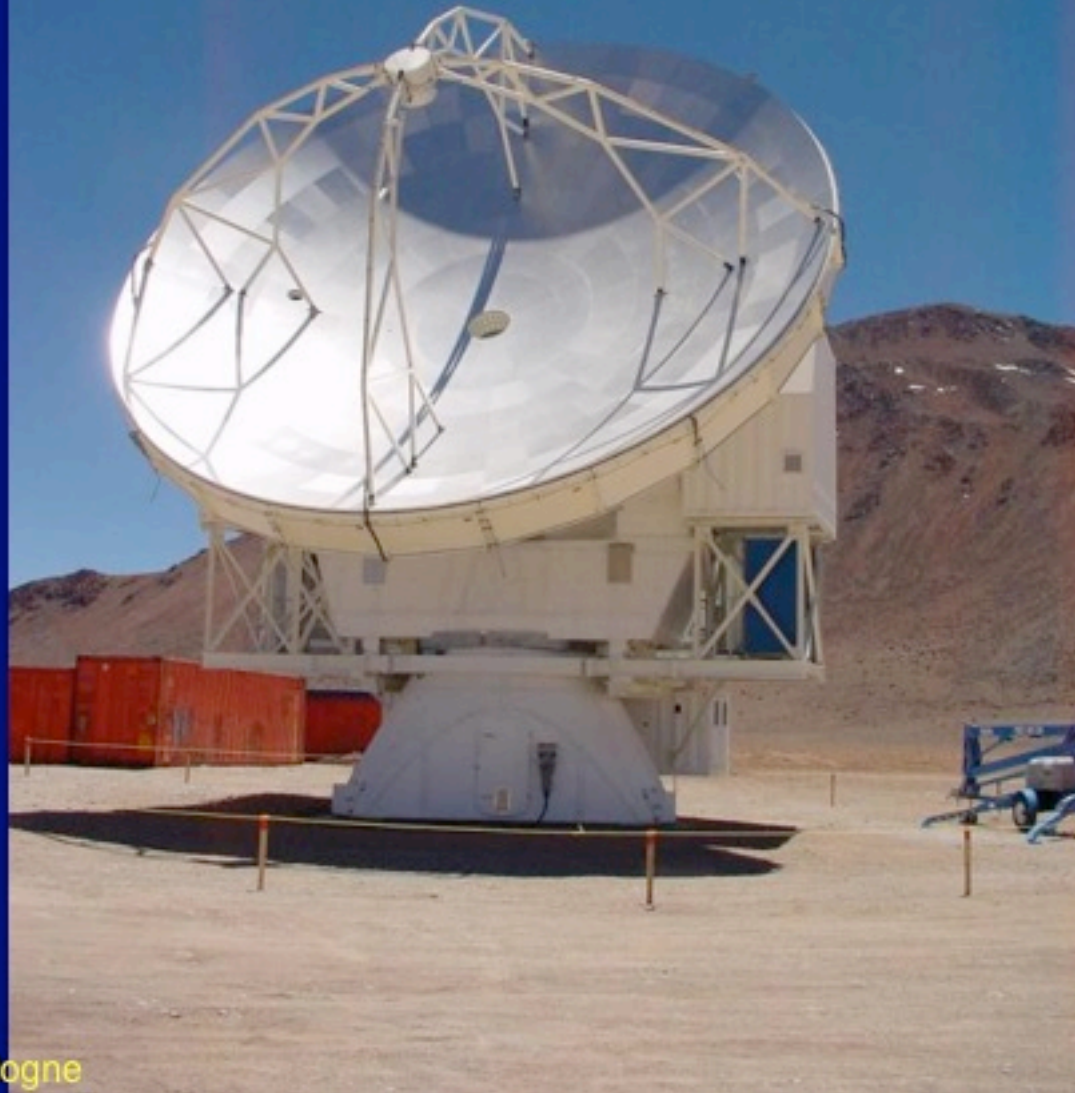

Image: University of Cologne

James Clerk Maxwell
Telescope, Mauna Kea,
Hawaii

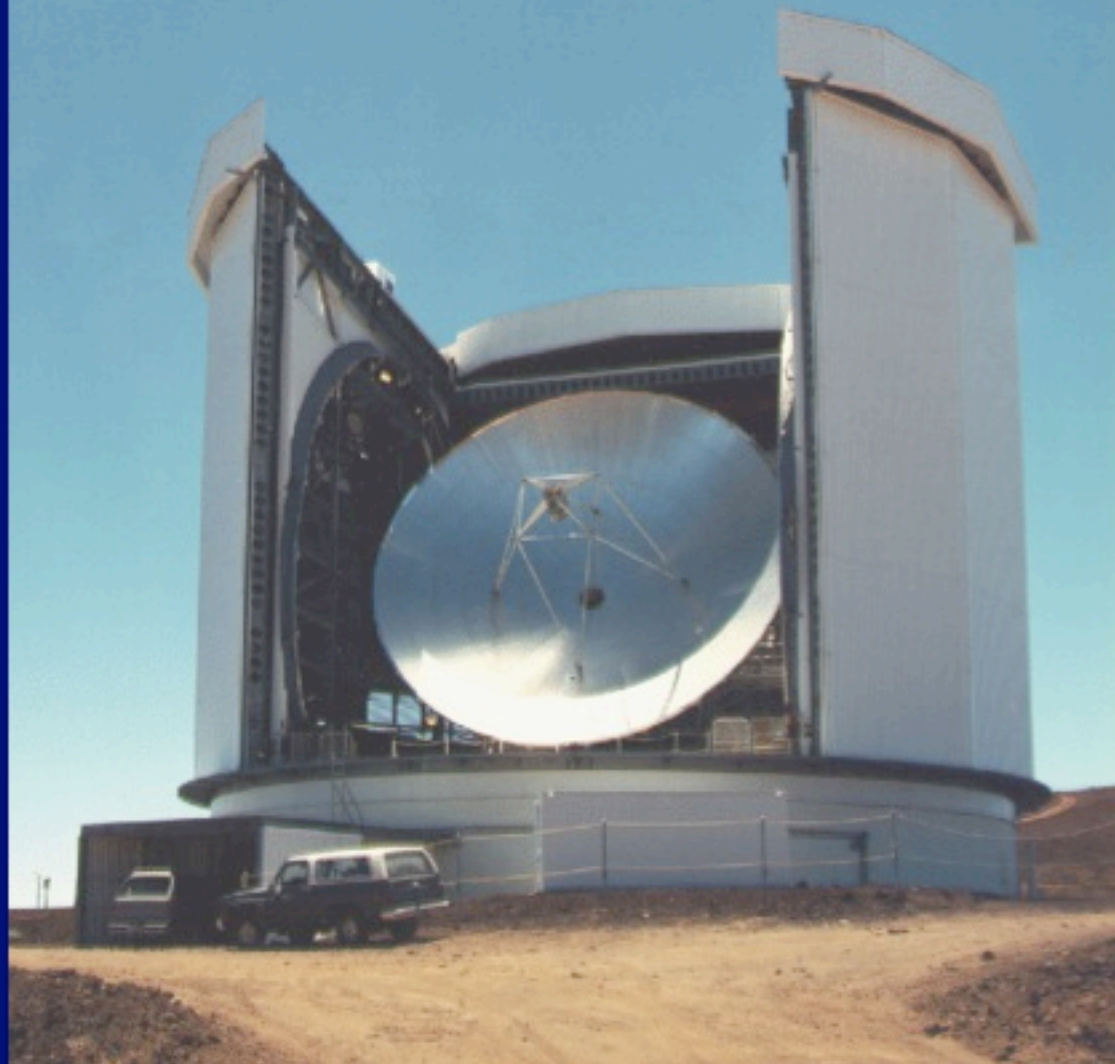

Image: JCMT

4 metre NANTEN2 telescope, Chajnantor, Chile



What was once the Heinrich Hertz Telescope



...is now the Sub-
Millimeter Telescope.



Image: University of Arizona, T.W. Folkers

This is an experimental greenhouse to see if antennas can be grown under Antarctic conditions.



Image: Seth White

Not all antennas are fully steerable

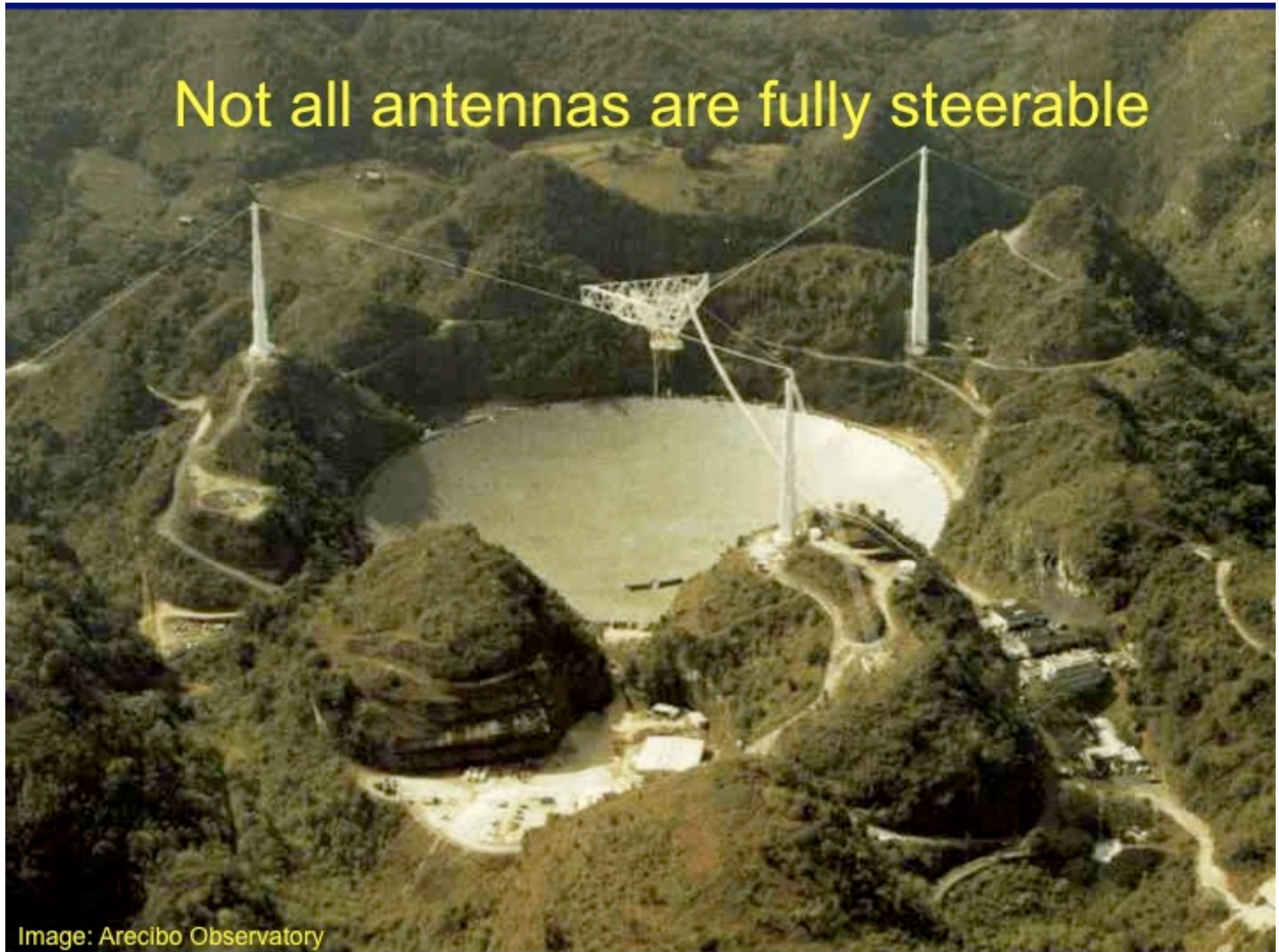
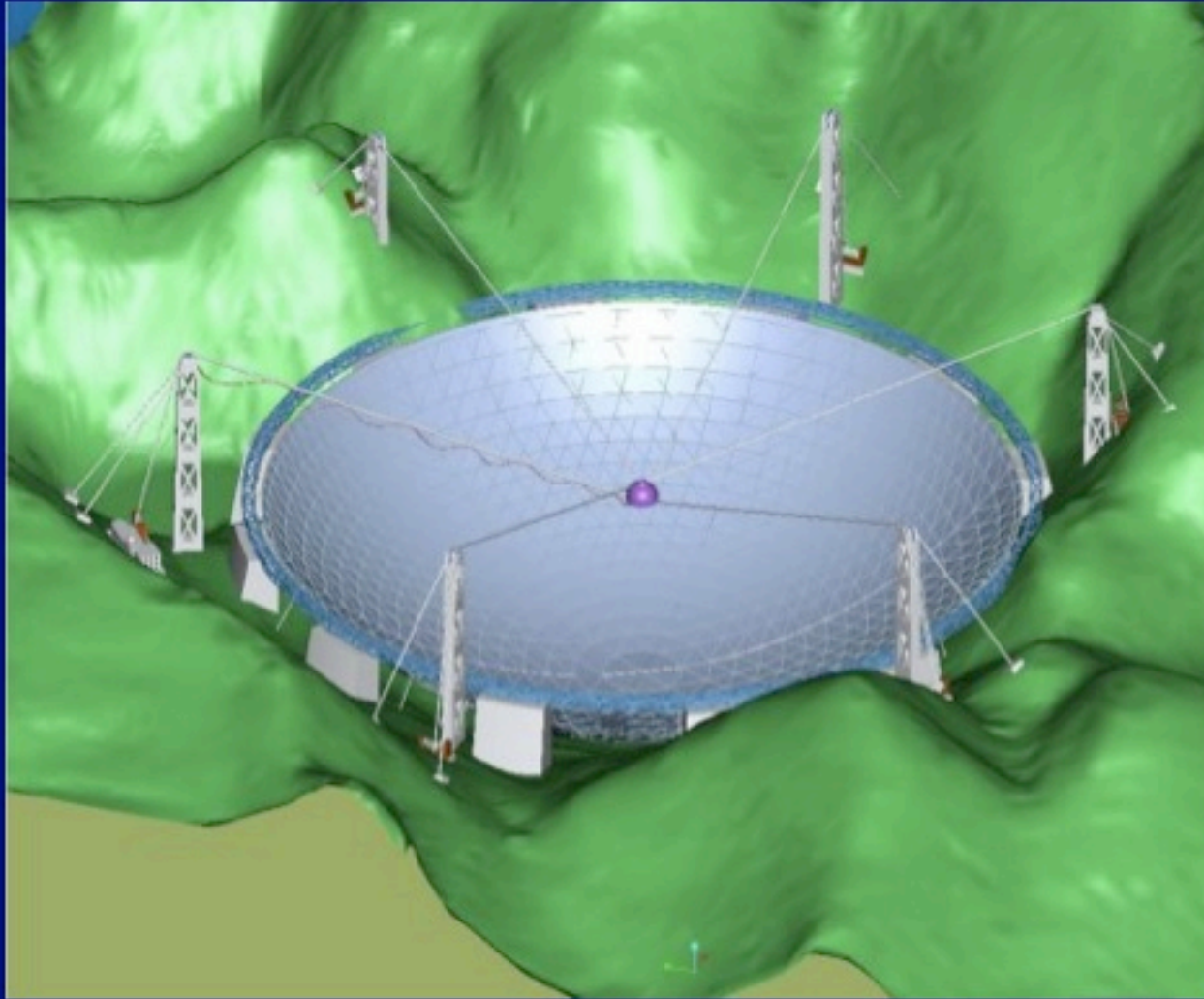

Image: Arecibo Observatory

FAST, 500 metres, China



Ground breaking ceremony for FAST, China.

Jan 27, 2009



“A journey of a thousand miles begins with a single step.” Confucius (551 BC - 479 BC).

Some telescopes are fully steerable, but only in a funny sort of way.



Mt Pleasant
Observatory, Tasmania

“Alt - over - Alt”

Image: Steve & Dorothy Darden

140 foot telescope, Greenbank, USA



This is a classic equatorial mount. Not even optical telescopes are built this way any more.

This one moved only in elevation.



The Greenbank 300 foot shortly after commissioning.

Image: NRAO

Then it stopped moving altogether...



The Greenbank 300 foot after a particularly bad observing run.

Image: NRAO

Outline

- Dipoles and quarter waves
- Low-frequency antennas
- Horn antennas
- **Dish antennas**
 - Surface accuracy
 - **Off-axis antennas**
- Interferometers

Off-axis telescopes

Or, what's that big feed thingy doing in the middle of my beautiful dish?

Image: Arecibo Observatory

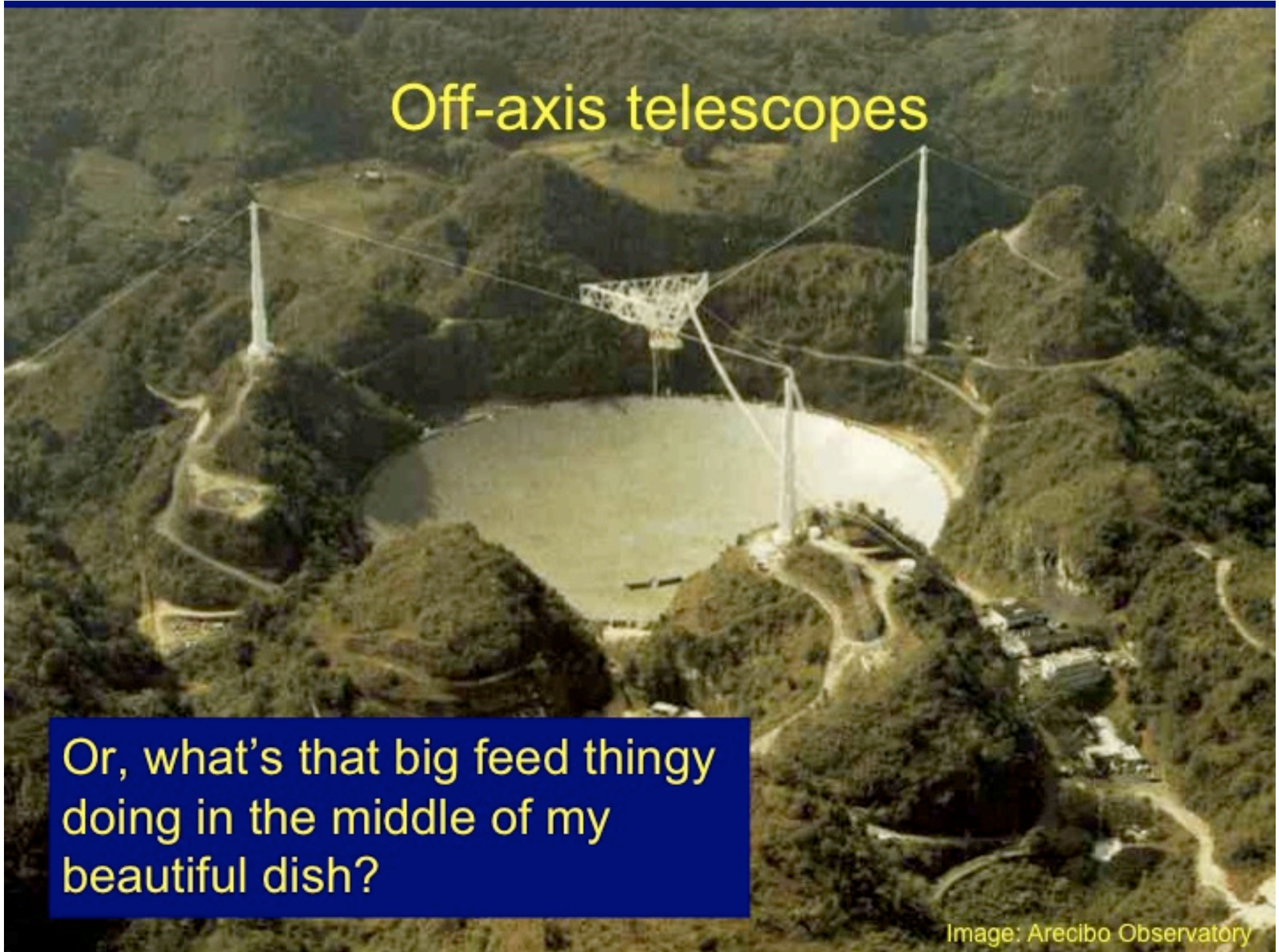



Image: Manolis Kellis

Aperture distributions

The antenna pattern is the Fourier transform of the aperture distribution

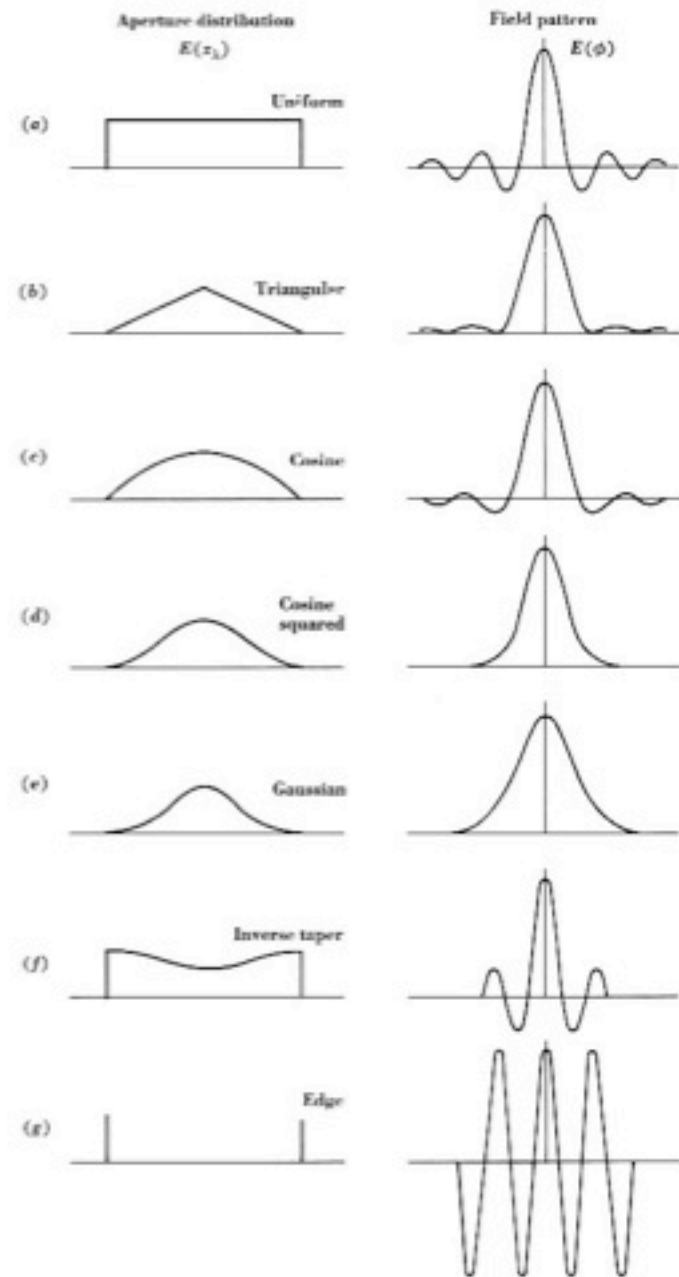

Fig. 6-9. Different aperture distributions with associated antenna patterns.

An on-axis prime focus antenna for satellite TV



Image: Raymarine

An off-axis prime focus antenna for satellite TV



Image: Winegard

The Greenbank 100m telescope

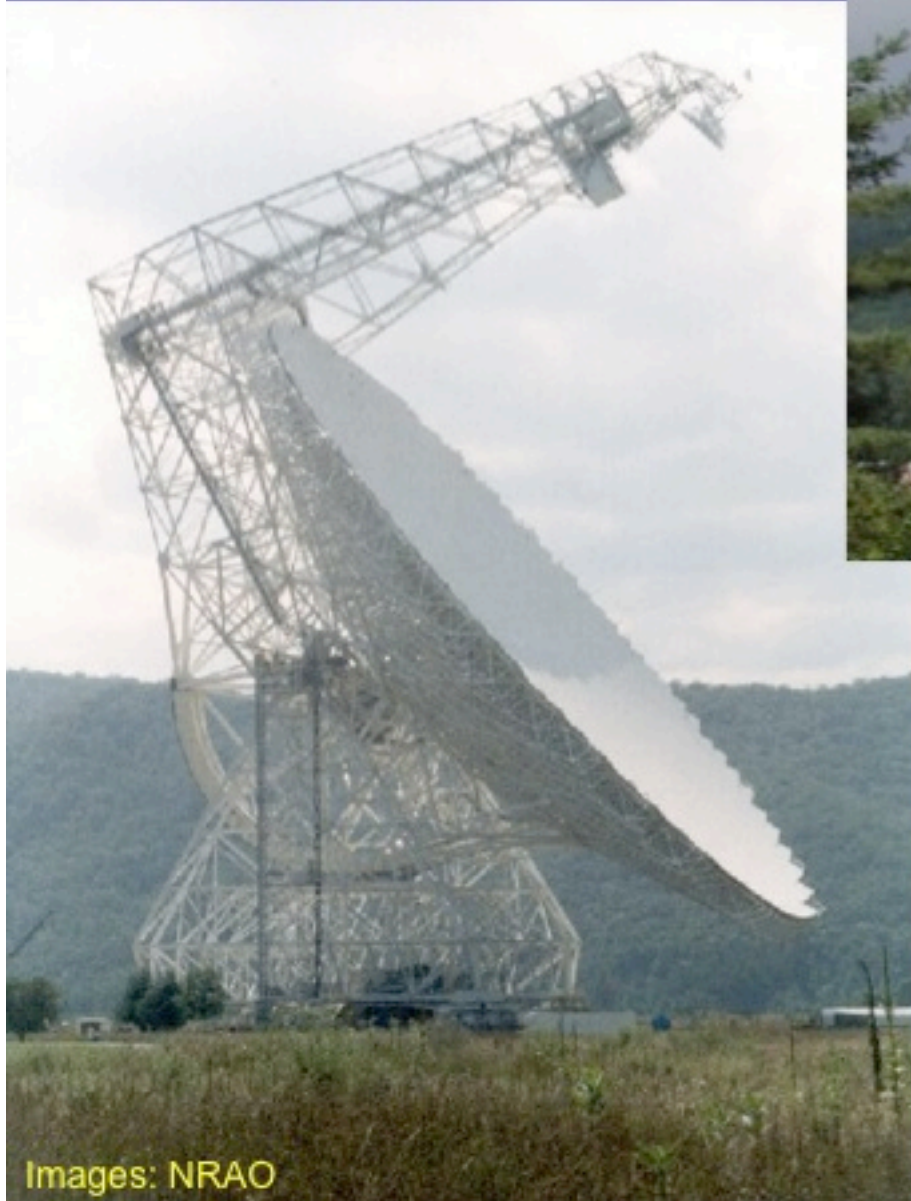

Images: NRAO



AST/RO

A photograph showing a man in a red jacket and blue pants working on a large, complex piece of scientific equipment on the lunar surface. The equipment is mounted on a metal structure and features a large, circular, metallic component. The background shows the blue-tinted lunar surface and a small structure in the distance. The word "VIPER" is written in yellow text on a dark blue rectangular background in the center of the image.

VIPER

Image: Paolo Calisse

The “South Pole Telescope” is a 10m offset Gregorian sub-mm telescope.

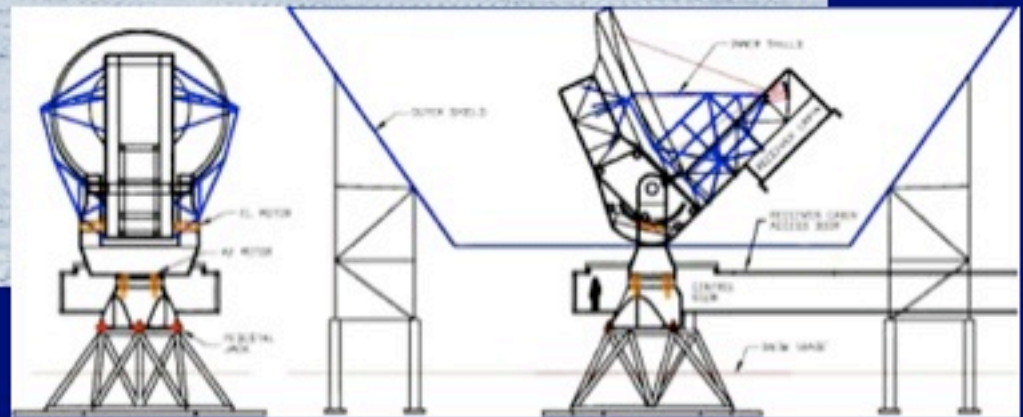
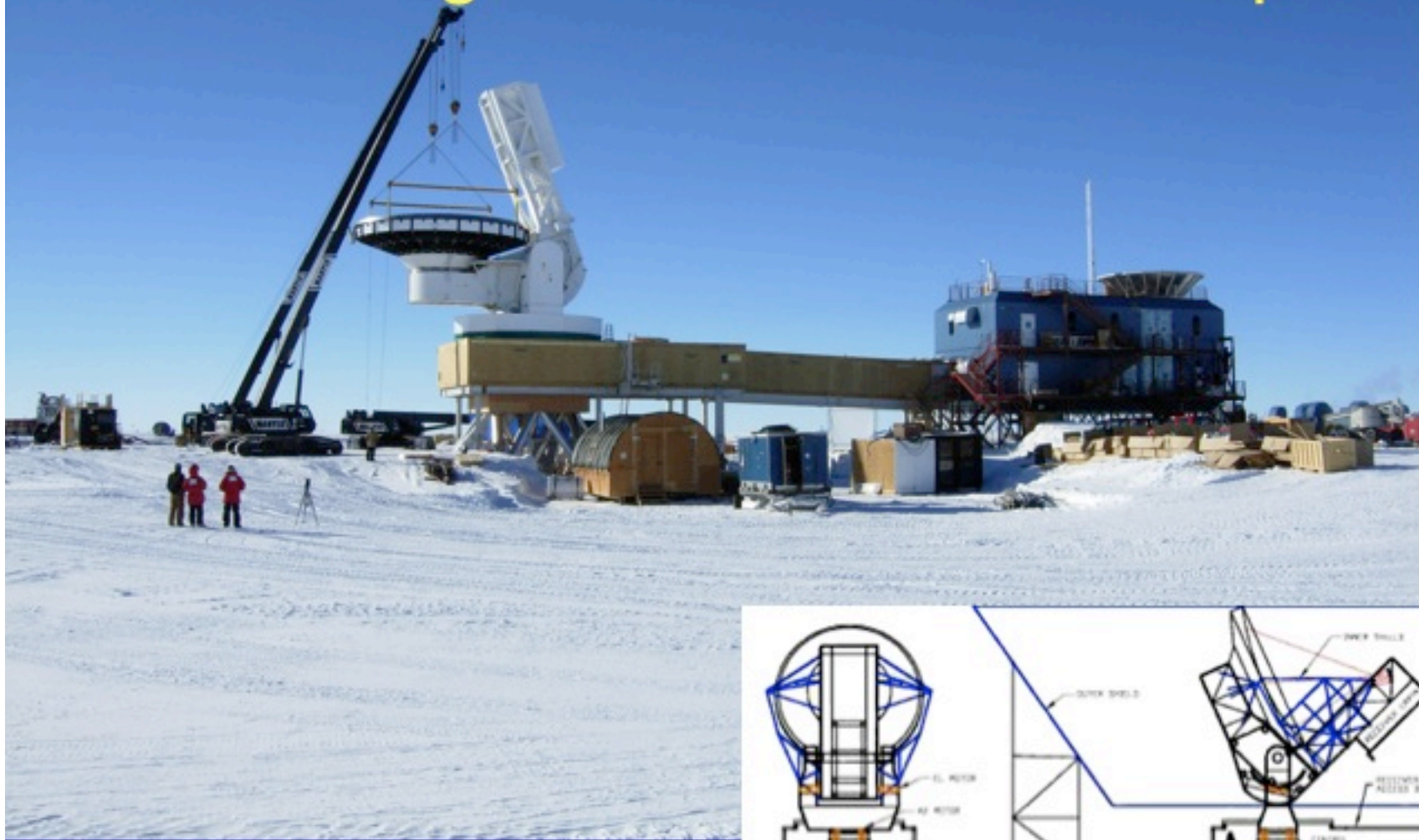

Image: South Pole Telescope



Image: South Pole Telescope

Outline

- Dipoles and quarter waves
- Low-frequency antennas
- Horn antennas
- Dish antennas
 - Surface accuracy
 - Off-axis antennas
- **Interferometers**

Interferometers

Interferometers are now used at all wavelengths from metre waves to the optical.

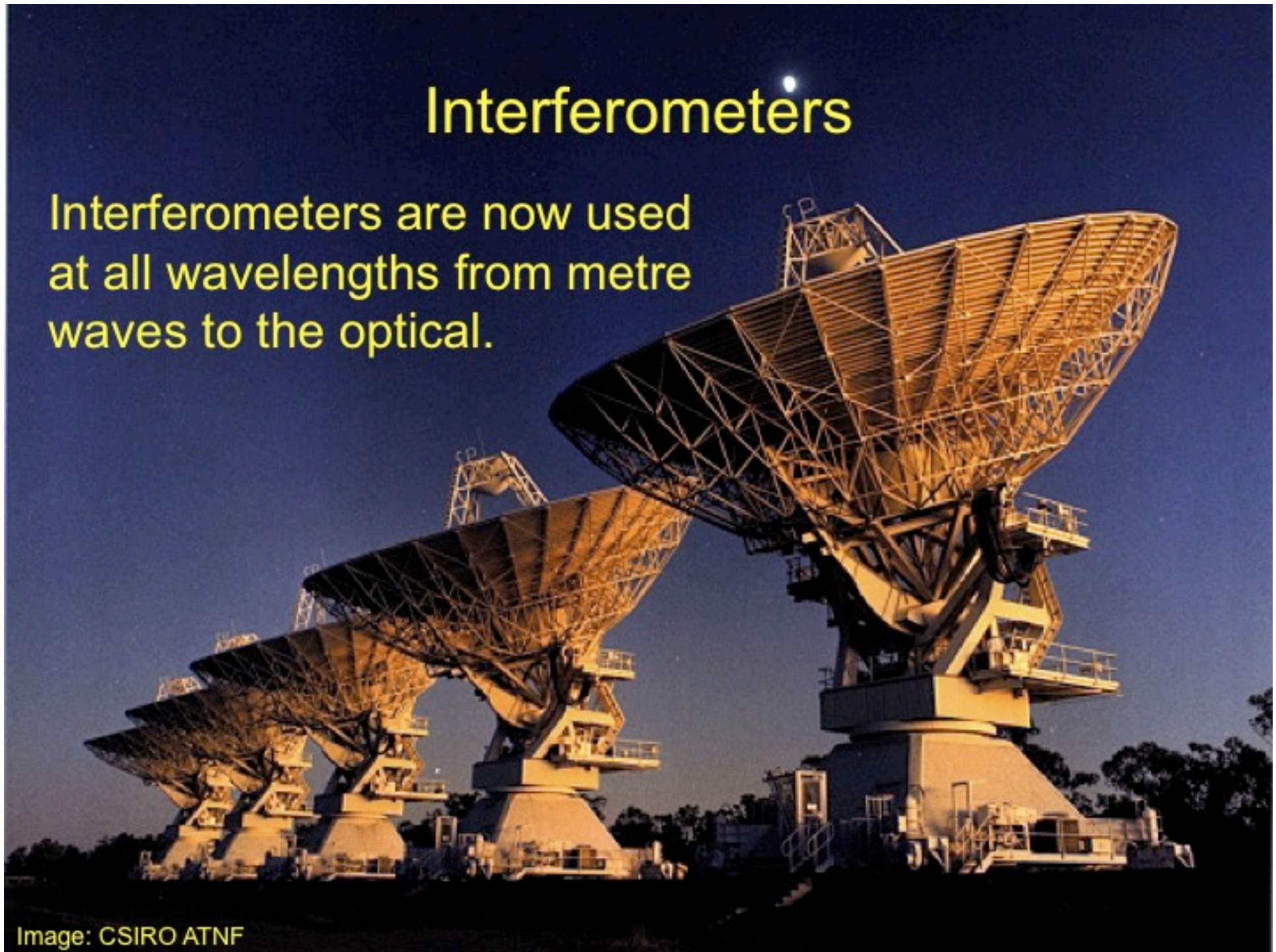

Image: CSIRO ATNF

The ATNF Compact Array at Narrabri is a particularly fine example.



Image: CSIRO ATNF

ASKAP will be even
more splendid.

Image: Paul Bourke



The Very Large Array (VLA), New Mexico.



Antennas are often planted in rows to make it easier for mechanical harvesters.

Image: NRAO

CARMA, Cedar Flat, California.

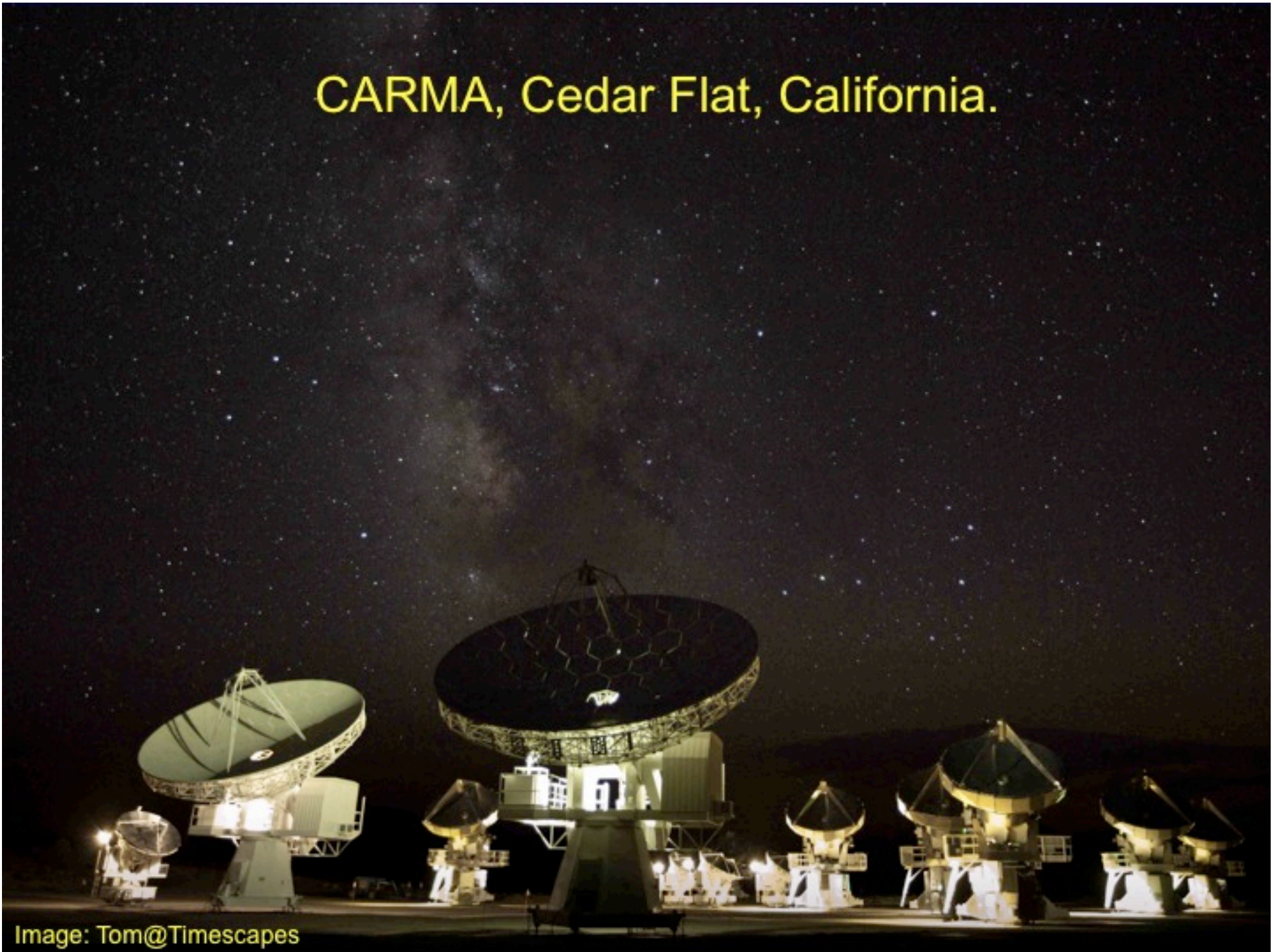

Image: Tom@Timescapes



IRAM, Plateau de Bure, France



The Sub-Millimeter Array (SMA), Mauna Kea

9/12/1999 18:34

Nobeyama Millimetre Array + ASTE sub-millimetre antenna



Image: <http://www.nro.nao.ac.jp/>

Chajnantor, Chile. 5,000 metre elevation.

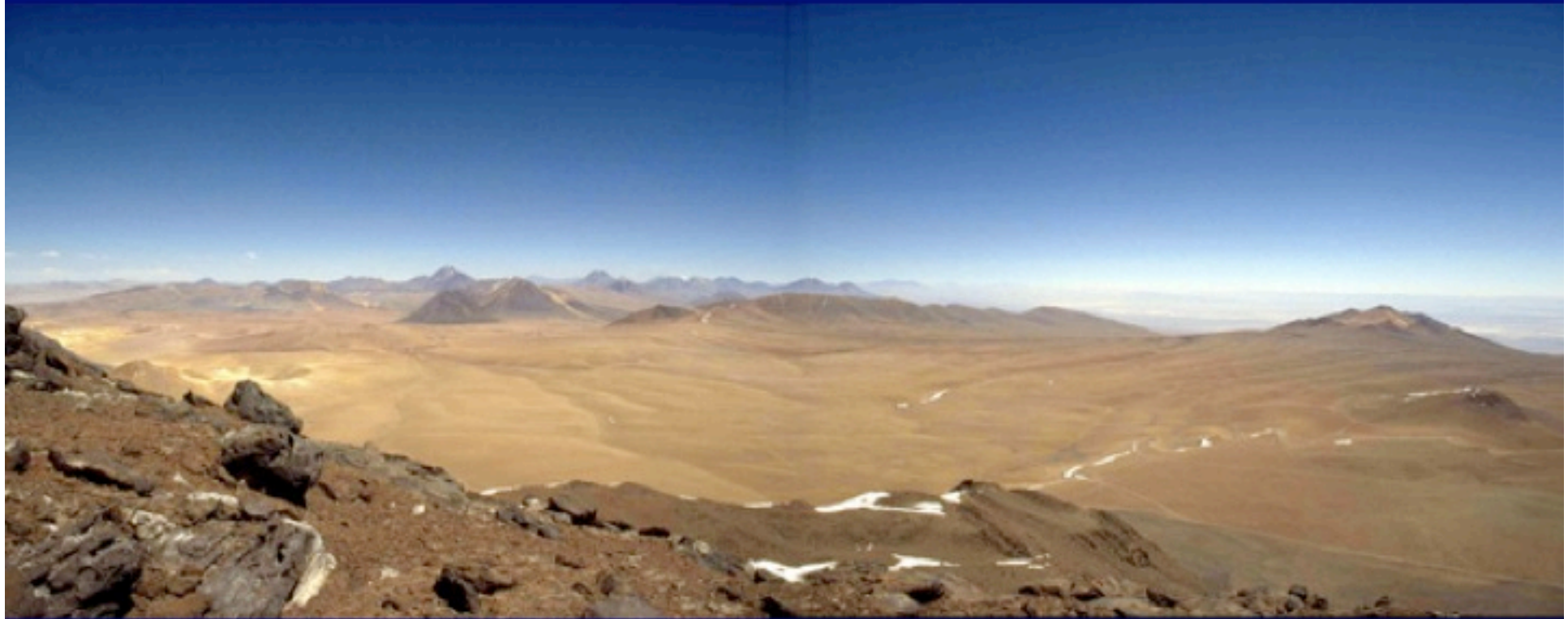

Astro-biologists are using GM techniques to develop high-altitude strains of antennas that can grow at these elevations.

ALMA will look like this...



Composite image: www.behance.net

...and the dishes will drive around on this.



Image: www.nrao.edu/

The first ALMA dish
was installed just a few
days ago!



Image: ALMA project

A final word on sub-mm telescopes

Sub-mm telescopes are placed in interesting places like Antarctica or on beautiful, remote mountain tops.

We pretend that this is because we need low water vapour.

So far, we've gotten away with this story.

Please don't tell...

Thank you

KOSMA, Switzerland

Image: Sap CEA

