



# Fourier Theory

## CASS Radio School

Joshua Marvil | OCE Postdoctoral Fellow

29 September, 2015

ASTRONOMY & SPACE SCIENCE

[www.csiro.au](http://www.csiro.au)



# **This talk is based on:**

## **The Fourier transform and its applications**

by Ronald N. Bracewell

## **Essential Radio Astronomy Course**

by J.J. Condon and S.M. Ransom

# Fourier Transforms are deeply ingrained in many aspects of radio interferometry

Antenna's primary beam

Array's synthesized beam

Frequency downconversion

Correlation, coherence & visibility

Convolution & deconvolution

***The goal of this talk is to reinforce key theoretical concepts in order to help you better understand applications of Fourier theory***

# Fourier series

A generalized series expansion of a function based on the special properties of a set of basis functions

*square wave*

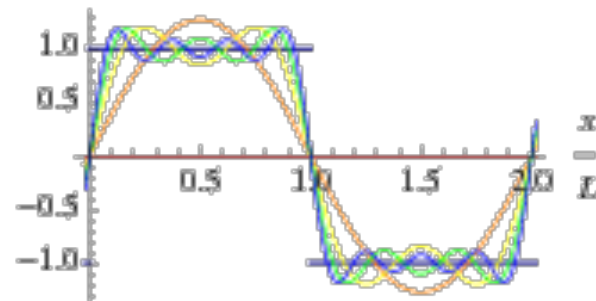

*sawtooth wave*

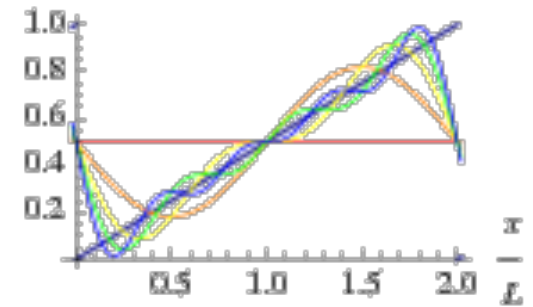

*triangle wave*

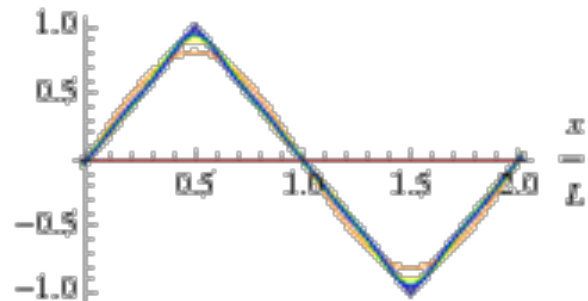

*semicircle*

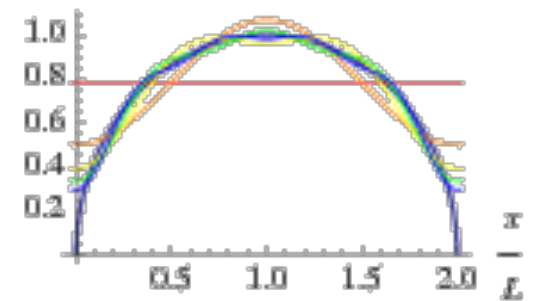

# Fourier series

For a periodic function  $f(x) = f(x+T)$ , choose sines and cosines with frequencies that are integer multiples of  $1/T$

Additional terms refine the approximation

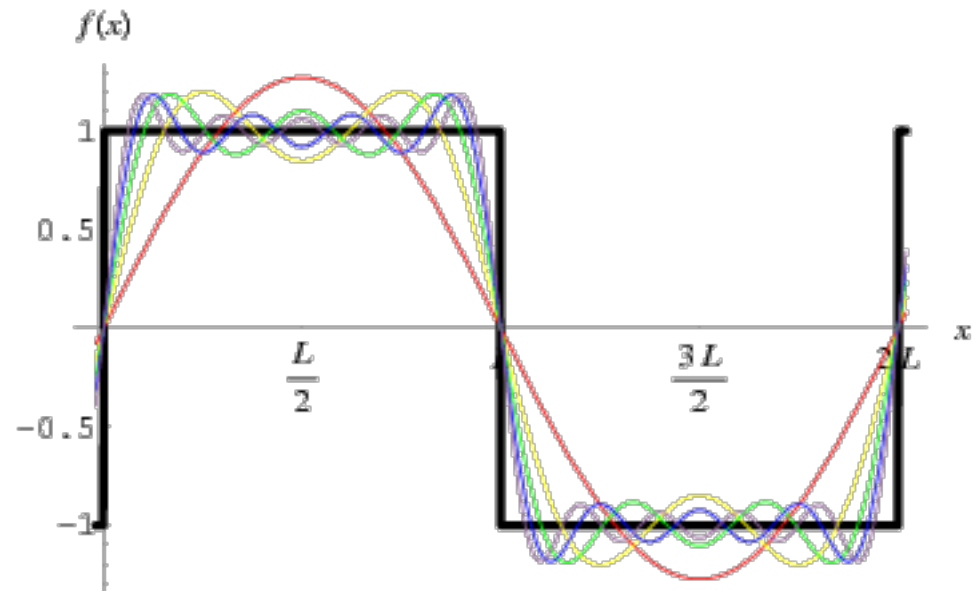

# Fourier series

This works very well for smooth functions

Discontinuities cause ringing (Gibbs phenomenon)

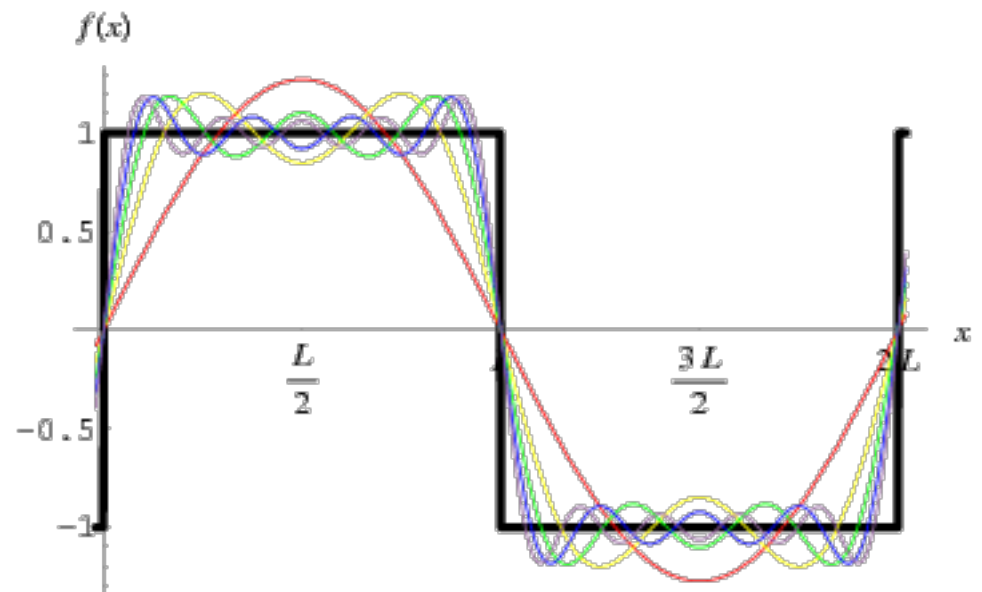

# Fourier series in practice

Solve for coefficients

$$a_m = \frac{2}{T} \int_0^T f(t) \cos\left(\frac{2\pi mt}{T}\right) dt$$

$$b_n = \frac{2}{T} \int_0^T f(t) \sin\left(\frac{2\pi nt}{T}\right) dt$$

and construct the series

$$f(t) = \frac{a_0}{2} + \sum_{m=1}^{\infty} a_m \cos\left(\frac{2\pi mt}{T}\right) + \sum_{n=1}^{\infty} b_n \sin\left(\frac{2\pi nt}{T}\right)$$

# Fourier series in practice

## Square wave solution

$$b_n$$

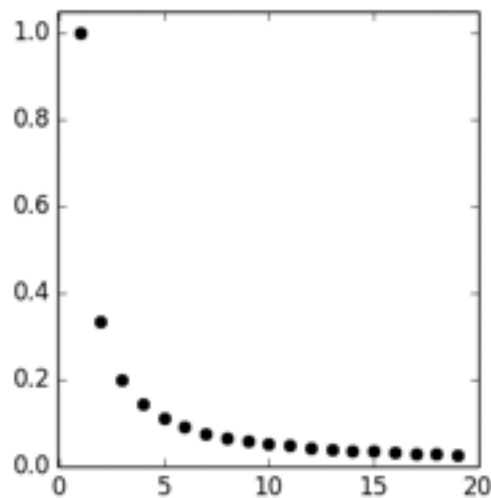

$$b_n \sin\left(\frac{2\pi n t}{T}\right)$$

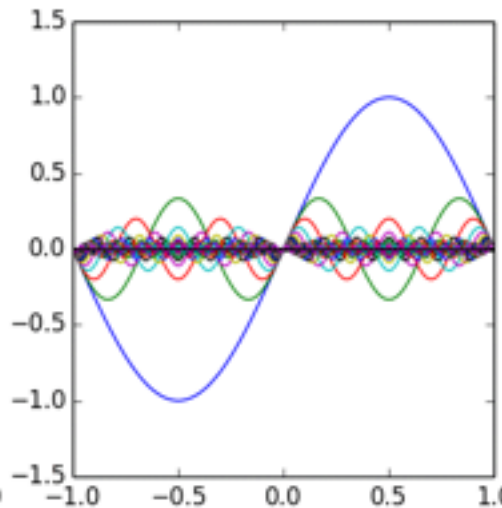

$$\sum_{n=1}^N b_n \sin\left(\frac{2\pi n t}{T}\right)$$

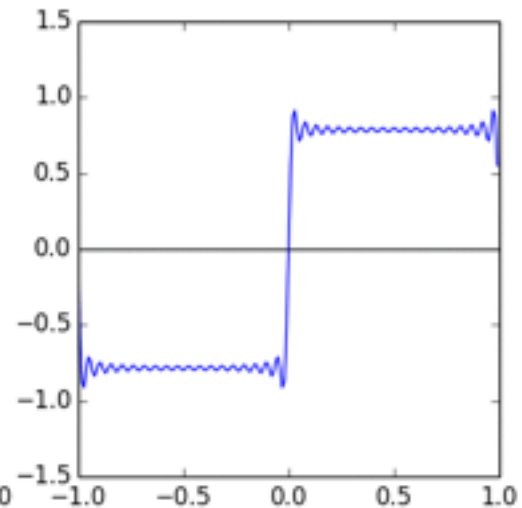

# Aside: even and odd functions

Decompose any function into even and odd parts

$$f(x) = e(x) + o(x)$$

$$e(x) = \frac{1}{2}(f(x) + f(-x)) \quad o(x) = \frac{1}{2}(f(x) - f(-x))$$

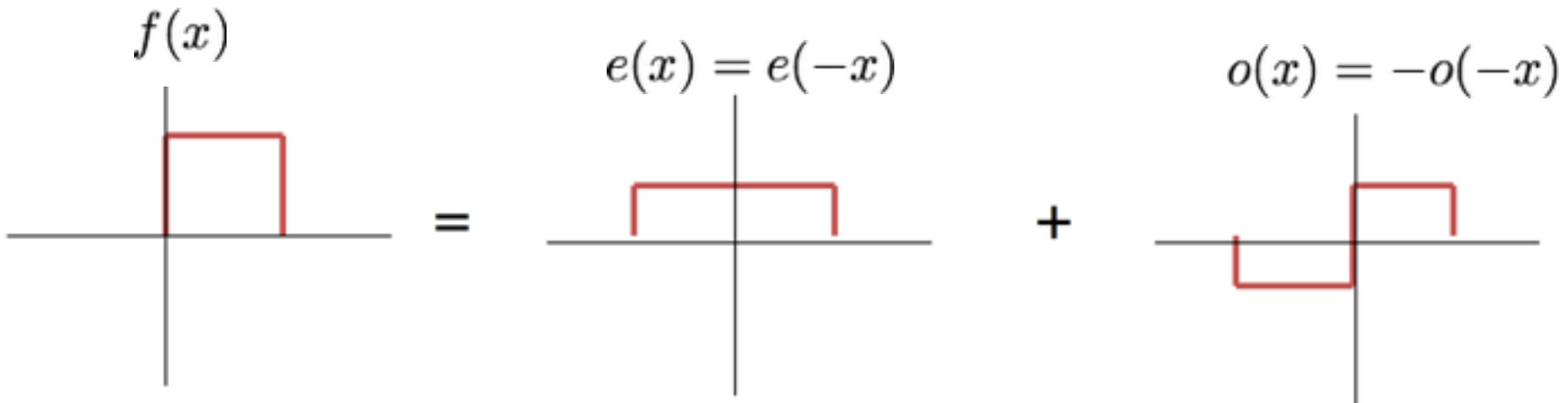

## Aside: Euler's formula

$$e^{it} = \cos t + i \sin t$$

Recast the Fourier series using complex notation

$$f(t) = \sum_{n=-\infty}^{\infty} c_n e^{\frac{2\pi i n t}{T}}$$

$$c_n = \frac{1}{T} \int_0^T f(t) e^{\frac{2\pi i n t}{T}} dt$$

# The Fourier Transform: Definitions

Generalize the complex Fourier series to work with non-periodic functions

Take the limit where where the period  $\longrightarrow$  infinity

The discrete sum becomes a continuous function

# The Fourier Transform: Definitions

The 'forward' transform:

$$F(s) \equiv \int_{-\infty}^{\infty} f(x) e^{-2\pi i s x} dx$$

The 'reverse' transform:

$$f(x) \equiv \int_{-\infty}^{\infty} F(s) e^{2\pi i s x} ds$$

# The Fourier Transform: Symmetry

The Fourier Transform is a reversible, linear transform between domains, e.g.  $\mathbf{x}$  and  $\mathbf{s}$ , where the product of  $\mathbf{x}$  and  $\mathbf{s}$  is dimensionless

$$f(x) \Leftrightarrow F(s)$$

$$f(x) = o(x) + e(x) = \mathbf{Re} o(x) + i\mathbf{Im} o(x) + \mathbf{Re} e(x) + i\mathbf{Im} e(x)$$



$$F(s) = O(s) + E(s) = \mathbf{Re} O(s) + i\mathbf{Im} O(s) + \mathbf{Re} E(s) + i\mathbf{Im} E(s)$$

# The Fourier Transform: Symmetry

$$f(x) \Leftrightarrow F(s)$$

<i>real</i>	<i>Hermitian</i>
<i>imaginary</i>	<i>anti-Hermitian</i>
<i>even</i>	<i>even</i>
<i>odd</i>	<i>odd</i>
<i>real and even</i>	<i>real and even</i>
<i>imaginary and even</i>	<i>imaginary and even</i>
<i>real and odd</i>	<i>imaginary and odd</i>
<i>imaginary and odd</i>	<i>real and odd</i>

# The Fourier Transform: Properties

## Linearity

If  $f(x) \Leftrightarrow F(s)$

then  $af(x) \Leftrightarrow aF(s)$

# The Fourier Transform: Properties

## Similarity theorem

If  $f(x) \Leftrightarrow F(s)$

then  $f(ax) \Leftrightarrow |a|^{-1} F(s)$

or equivalently  $|a|^{\frac{1}{2}} f(ax) \Leftrightarrow |b|^{\frac{1}{2}} F(bs)$

# The Fourier Transform: Properties

## Addition theorem

If

$$\begin{aligned} f(x) &\Leftrightarrow F(s) \\ g(x) &\Leftrightarrow G(s) \end{aligned}$$

then  $f(x) + g(x) \Leftrightarrow F(s) + G(s)$

# The Fourier Transform: Properties

## Shift theorem

If  $f(x) \Leftrightarrow F(s)$

then  $f(x - a) \Leftrightarrow e^{-i2\pi as} F(s)$

# The Fourier Transform: Properties

## Modulation theorem

If  $f(x) \Leftrightarrow F(s)$

then

$$f(x)\cos(\omega x) \Leftrightarrow \frac{1}{2}F(s - \omega/2\pi) + \frac{1}{2}F(s + \omega/2\pi)$$

# The Fourier Transform: Simple Functions

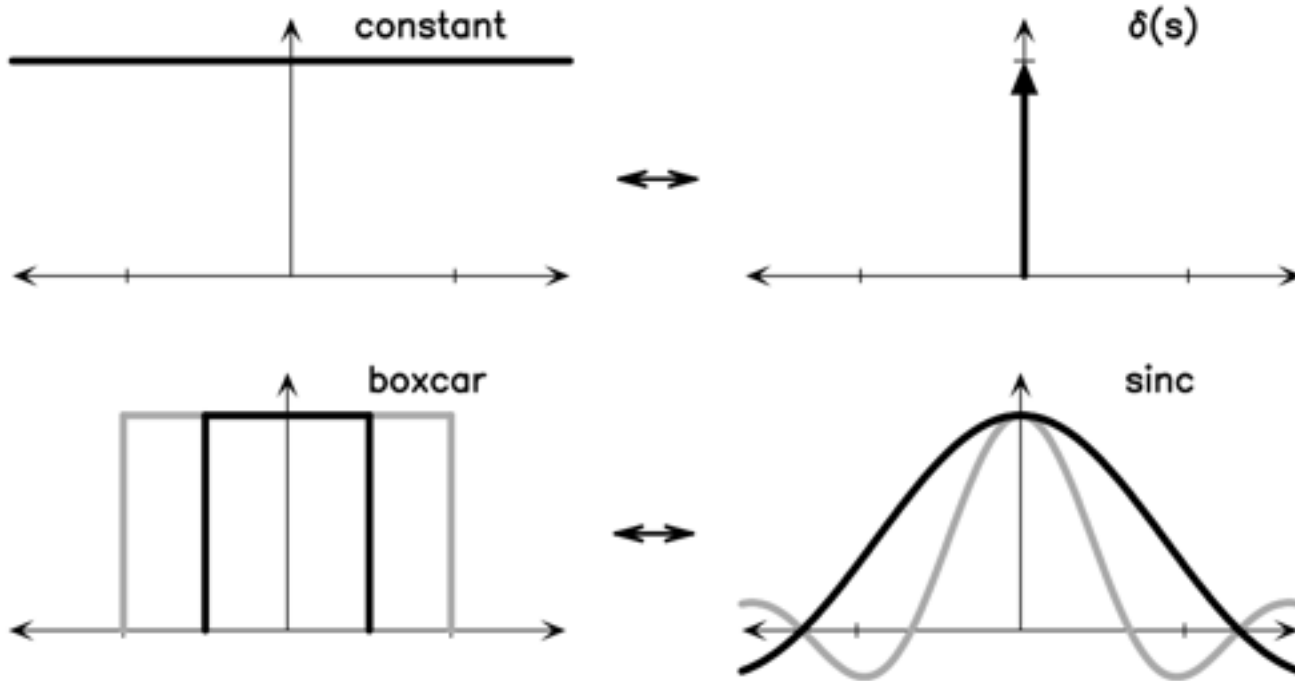

# The Fourier Transform: Simple Functions

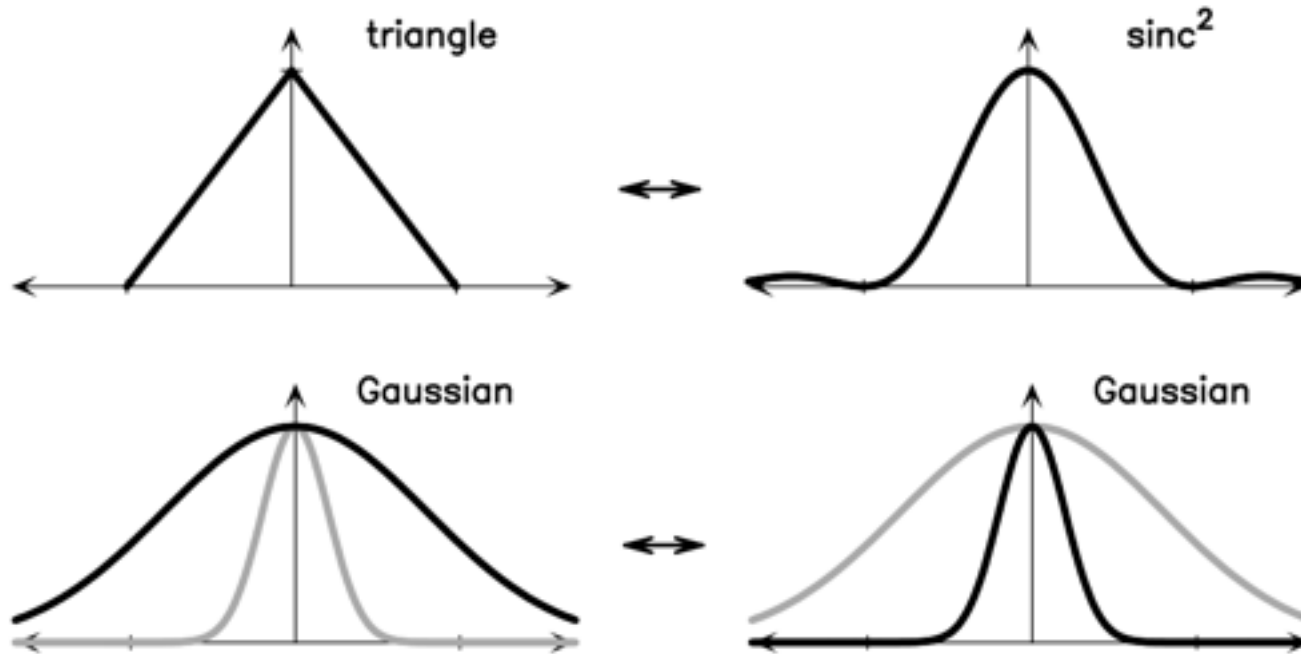

# The Fourier Transform: Simple Functions

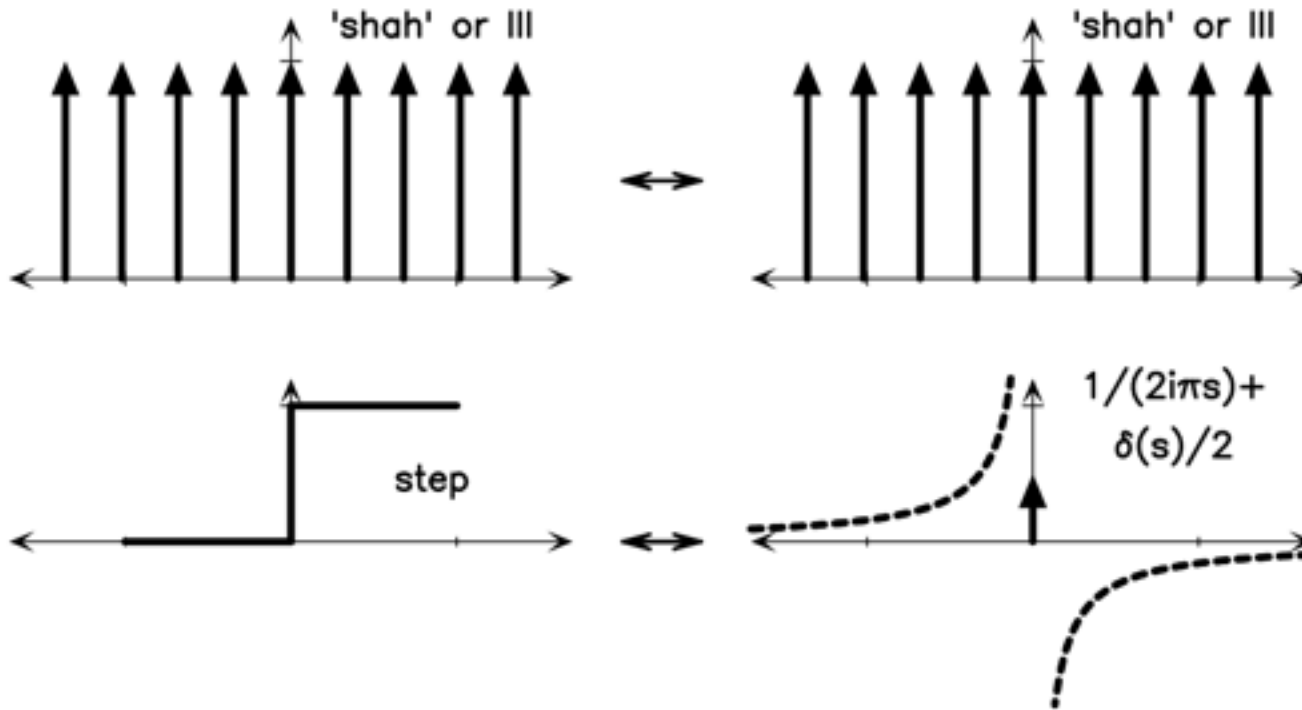

# The Fourier Transform: Simple Functions

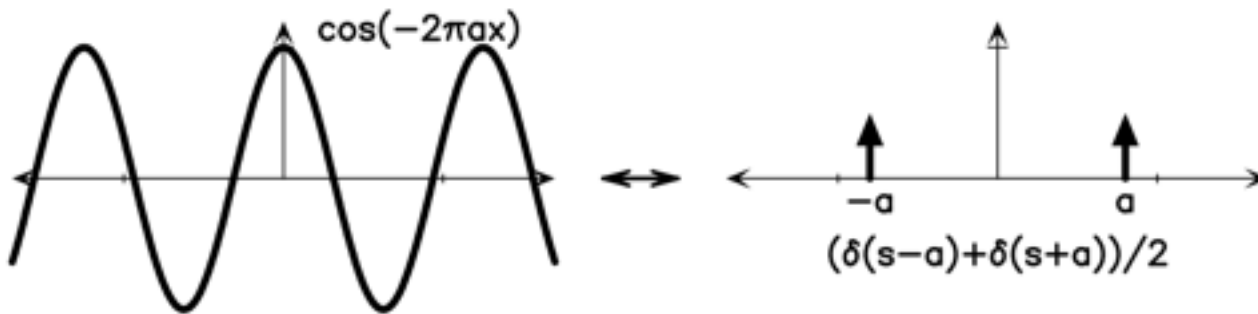
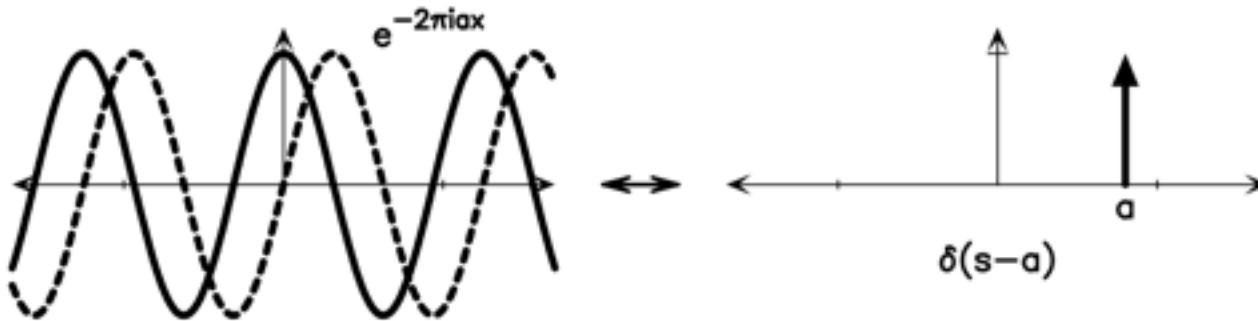

# Discrete Fourier Transform

So far we have been dealing with a continuous function  $f(x)$

For a set of  $N$  uniformly sampled data we can evaluate the DFT:

$$X_k = \sum_{j=0}^{N-1} x_j e^{-2\pi ijk/N} \quad x_j = \frac{1}{N} \sum_{k=0}^{N-1} X_k e^{2\pi ijk/N}$$

Produces  $N$  independent bins  $X_k = A_k e^{i\theta_k}$

Fourier transform properties and symmetries apply

# The Fast Fourier Transform (FFT)

- a family of algorithms to increase the speed of calculating a DFT
- reduces the number of computations from  $O(N^2)$  to  $O(N \log N)$
- recursive divide and conquer by re-using intermediate calculations

# The Fast Fourier Transform (FFT)

- interferometric images are typically made using an FFT of the gridded visibilities
- performance improves when the grid size is highly factorable
- see also: FFTPACK, FFTW

# Convolution

The function  $f$  is multiplied by the time-reversed kernel  $g$

$$h(x) = f * g \equiv \int_{-\infty}^{\infty} f(u)g(x - u) du$$

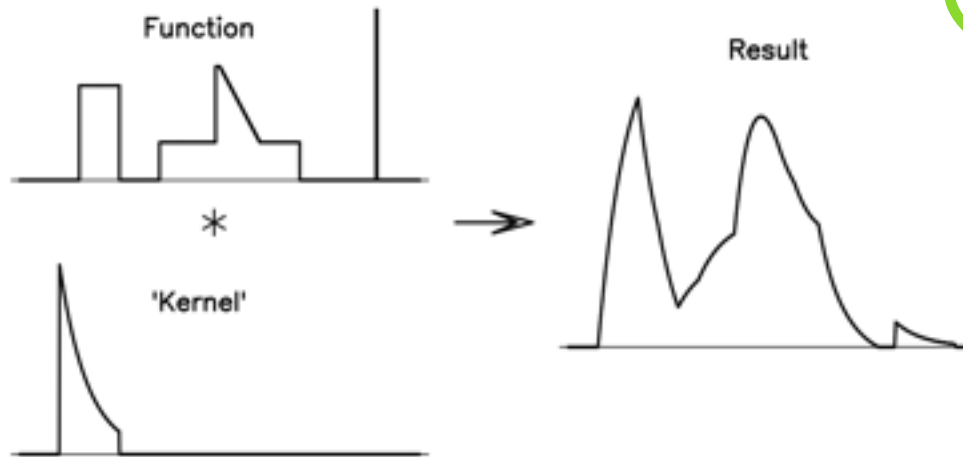

$$f * g \Leftrightarrow F \cdot G$$

# Fourier Transforms are deeply ingrained in many aspects of radio interferometry

Antenna's primary beam

Array's synthesized beam

Frequency downconversion

Correlation, coherence & visibility

Convolution & deconvolution

# Applications: Array synthesized beam

u-v coverage

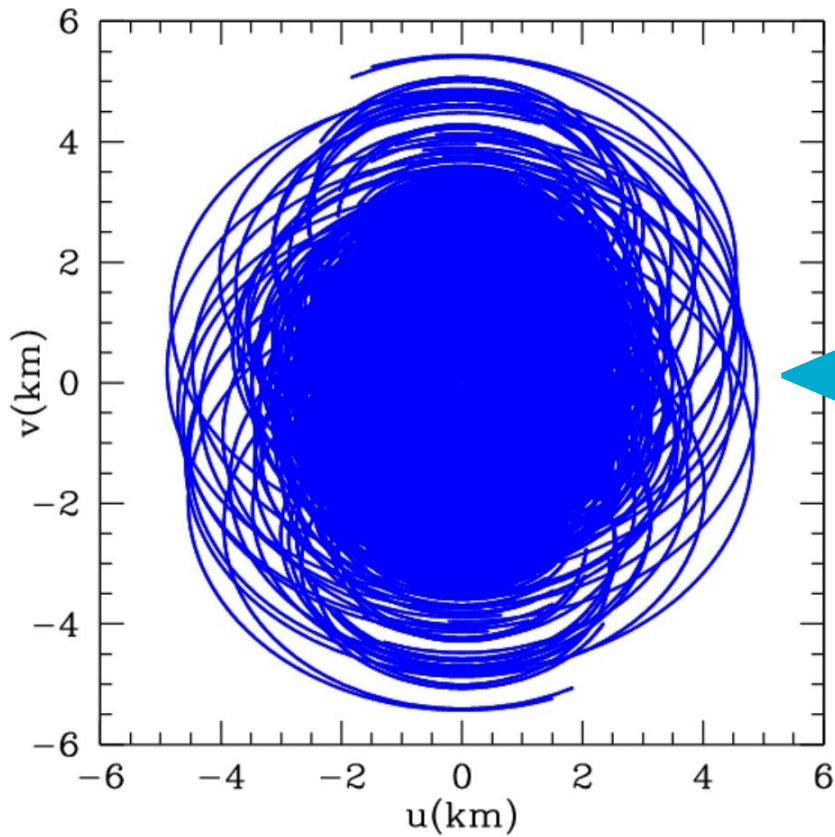

PSF

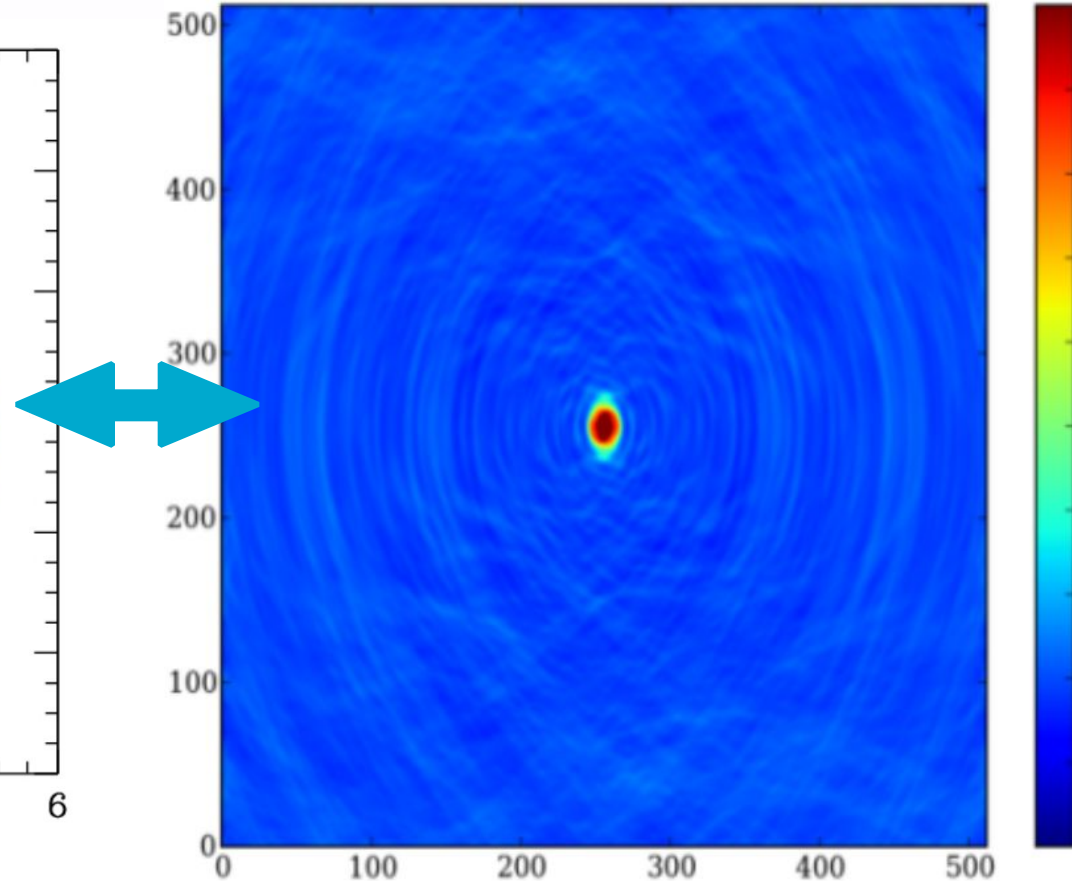

# Applications: Primary beam pattern

## 1-d aperture

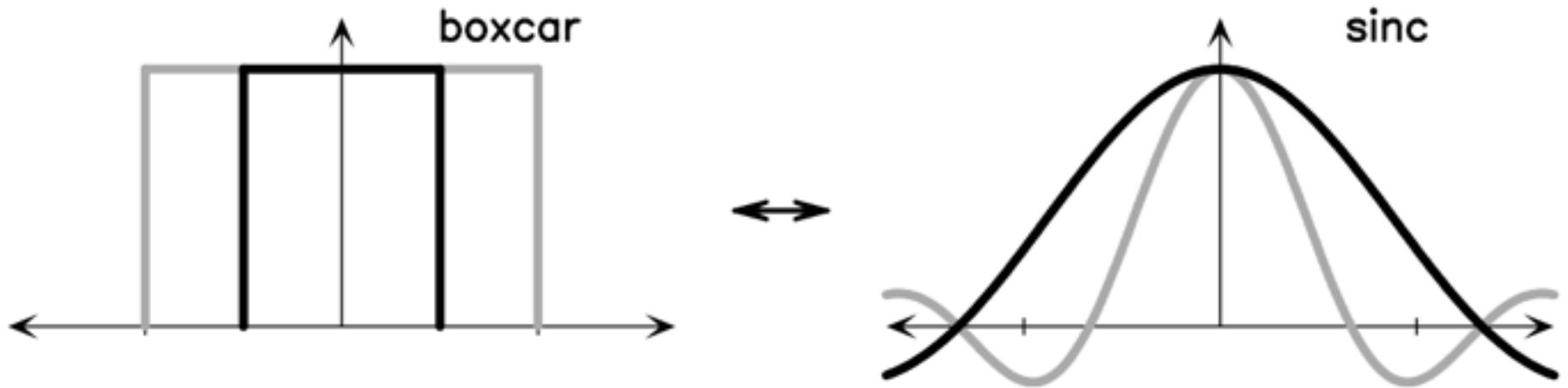

# Applications: Primary beam pattern

## 2-d aperture

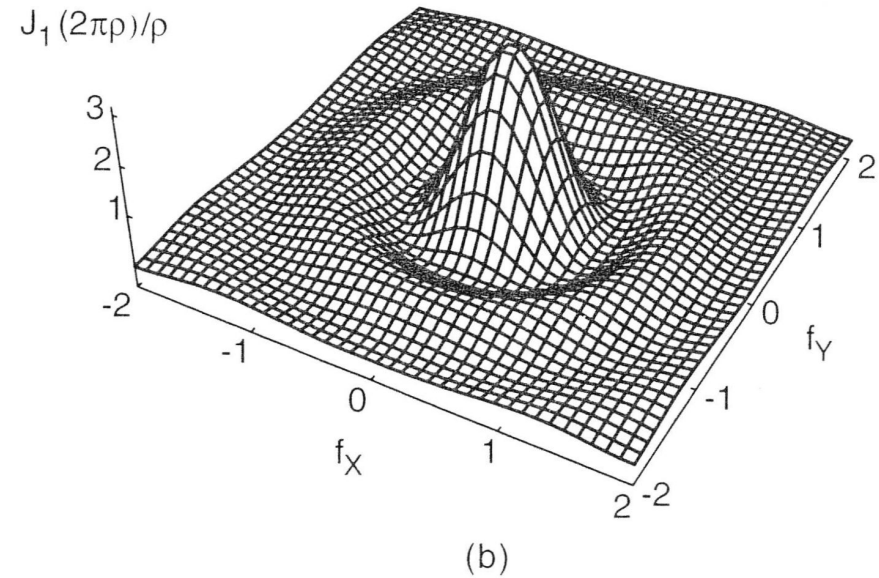
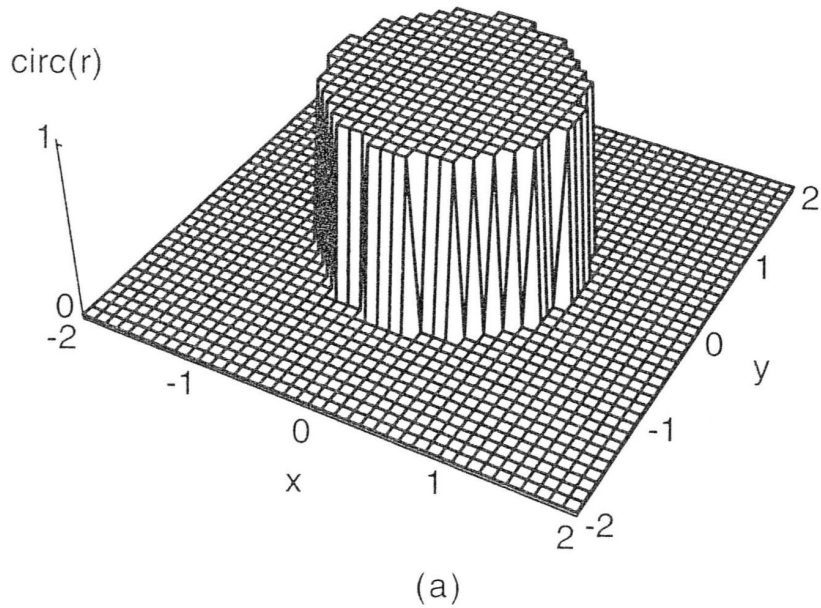
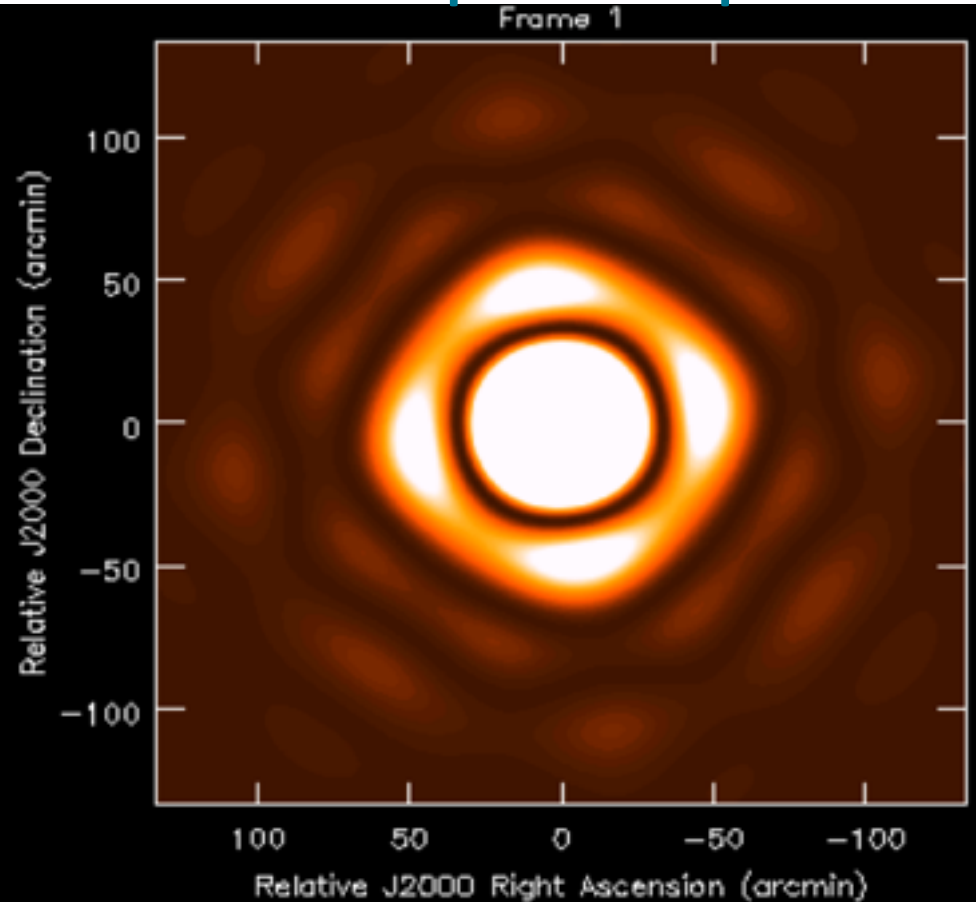
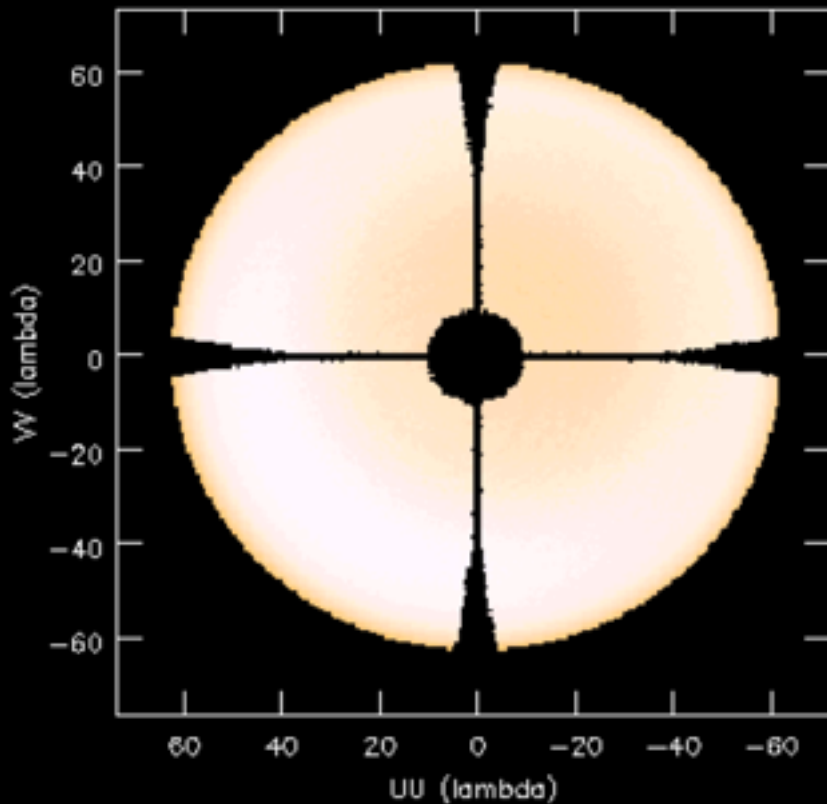

Figure 2.3 The circle function and its transform.

# Applications: Primary beam pattern

aperture illumination

antenna power pattern



# van Cittert-Zernike Theorem

$$V(u, v) = \iint A(l, m) B(l, m) e^{-2\pi i(ul + mv)} dl \cdot dm$$

$B(l, m)$  := sky brightness in direction  $l, m$

$A(l, m)$  := antenna reception pattern

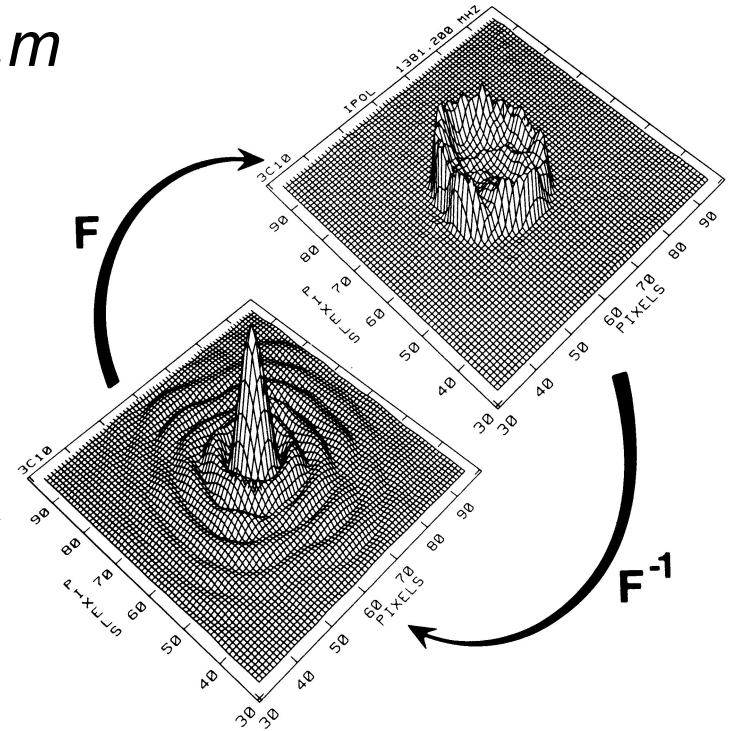

# van Cittert-Zernike Theorem

$$V(u, v) = \iint A(l, m) B(l, m) e^{-2\pi i(ul + mv)} dl \cdot dm$$

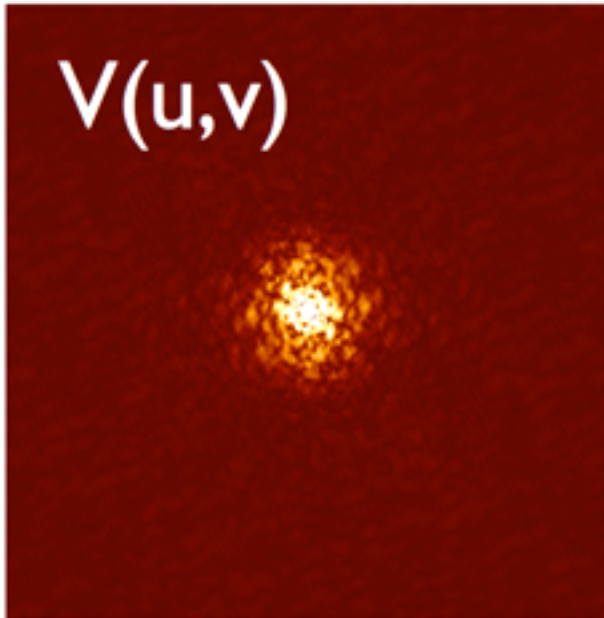

FT  
↔

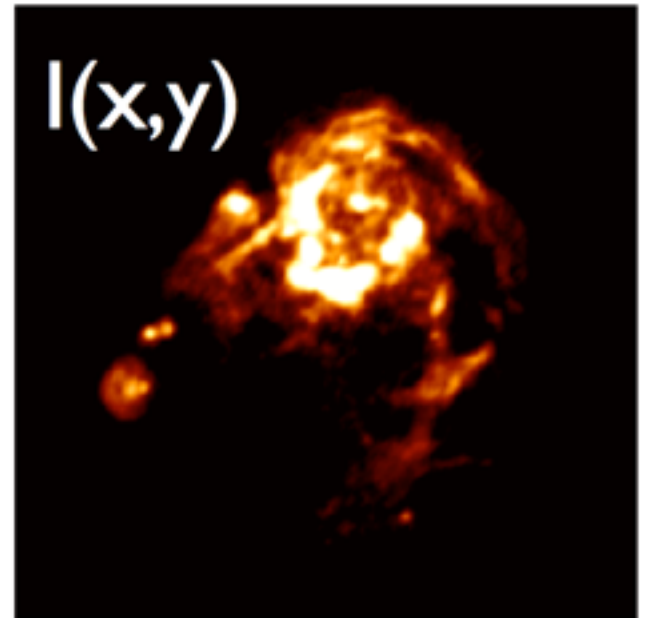

# Applications: Convolution



**Output = Input  $\star$  Impulse Response**

**Impulse Response = Point Spread Function**

**With knowledge of the PSF we can undo the convolution and estimate the original input**

# Thank you

**CSIRO Astronomy & Space Science**

Joshua Marvil | OCE Postdoctoral Fellow

t +61 2 9372 4329

e [josh.marvil@csiro.au](mailto:josh.marvil@csiro.au)

[www.csiro.au](http://www.csiro.au)

