

Radio Telescope Receivers

Alex Dunning

25th September 2017

CSIRO ASTRONOMY AND SPACE SCIENCE
www.csiro.au



“A radio receiver is an electronic device that receives radio waves and converts the information carried by them to a usable form”

Wikipedia



Ours look more like this

- Captures the signal reflected from the antenna
- Determines the beam shape
- Amplifies the signal
- Conditions the signal for digitisation

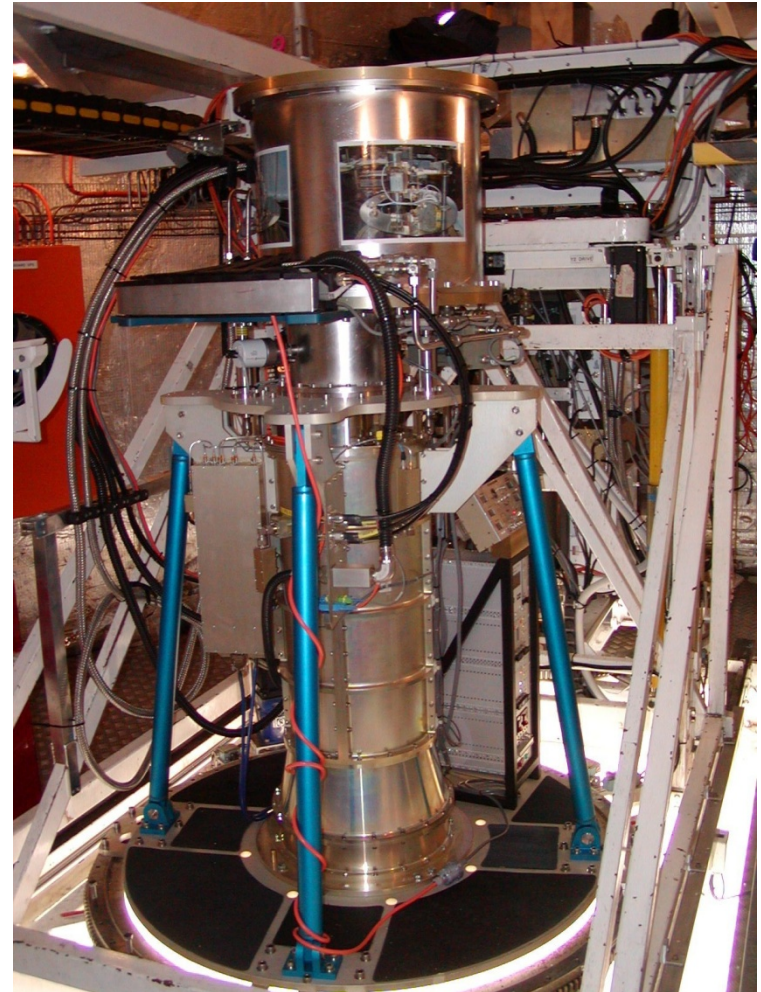

Parkes 10/40cm Receiver

On the outside...

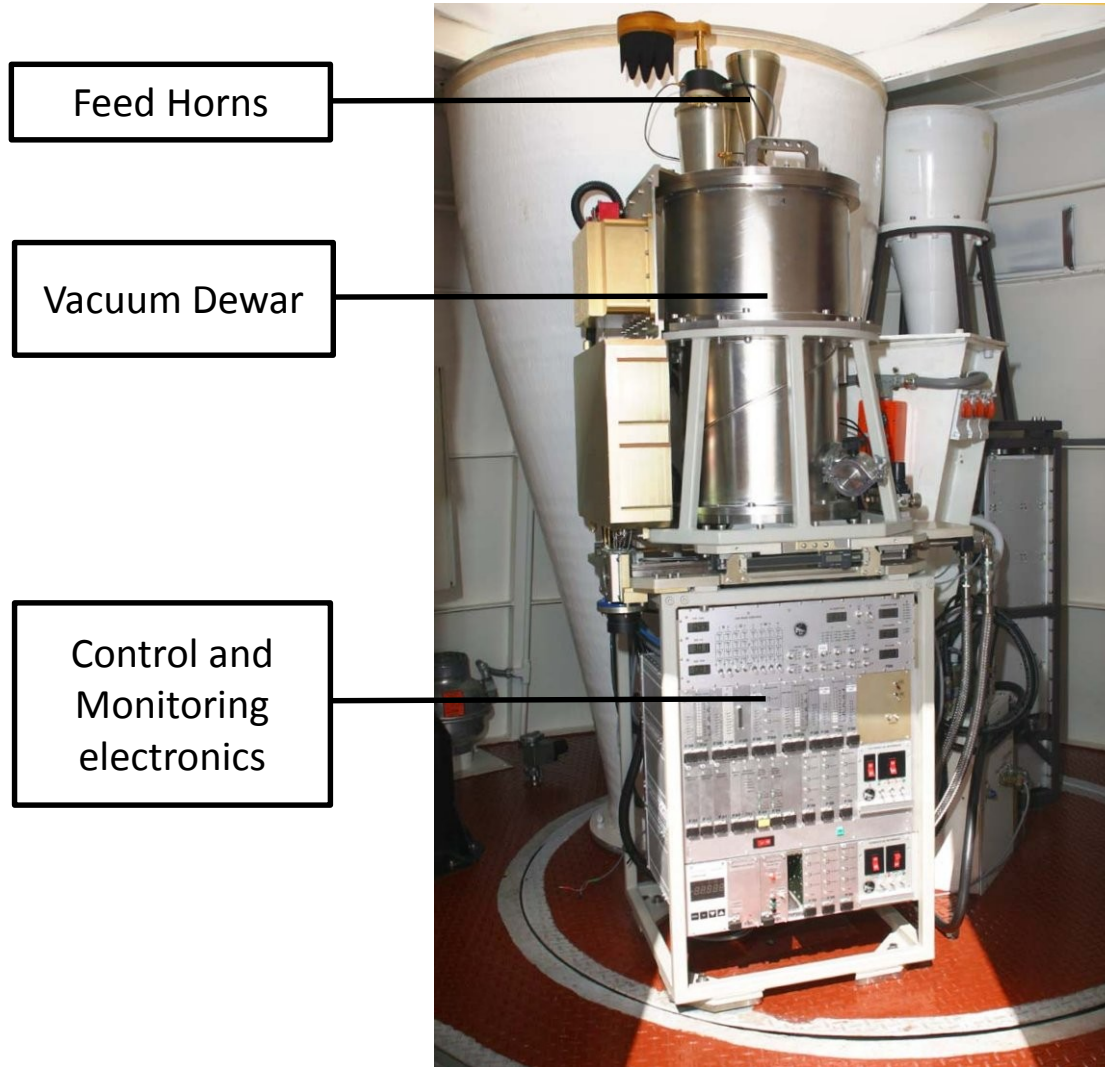

On the inside...

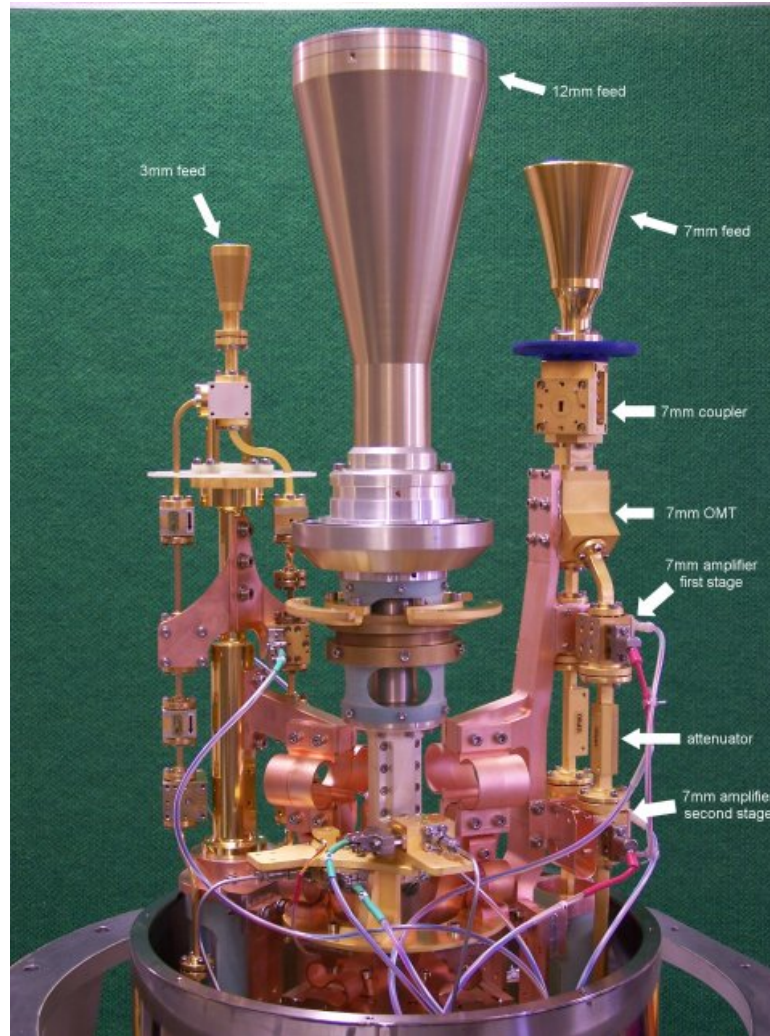

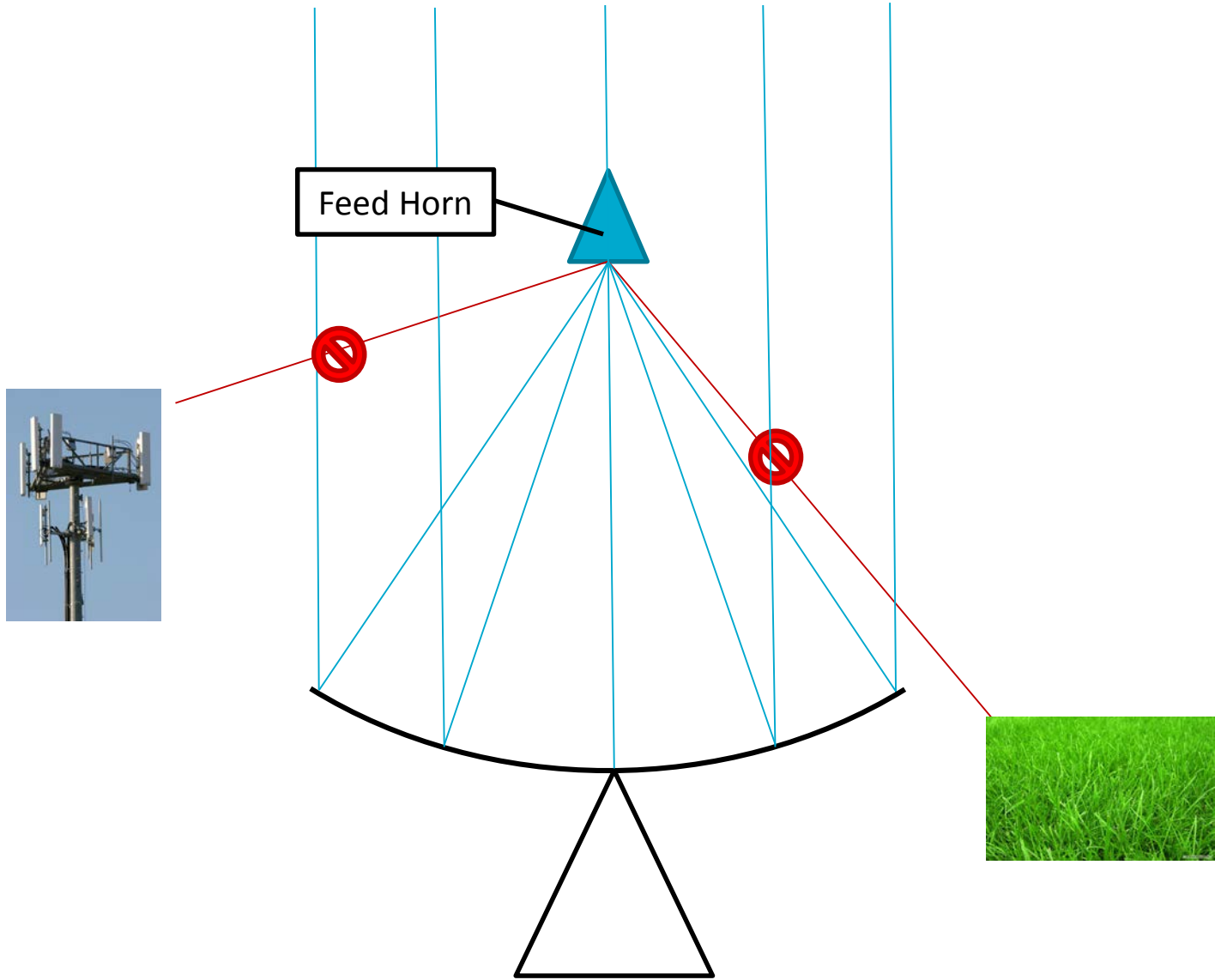

Detour: Reciprocity

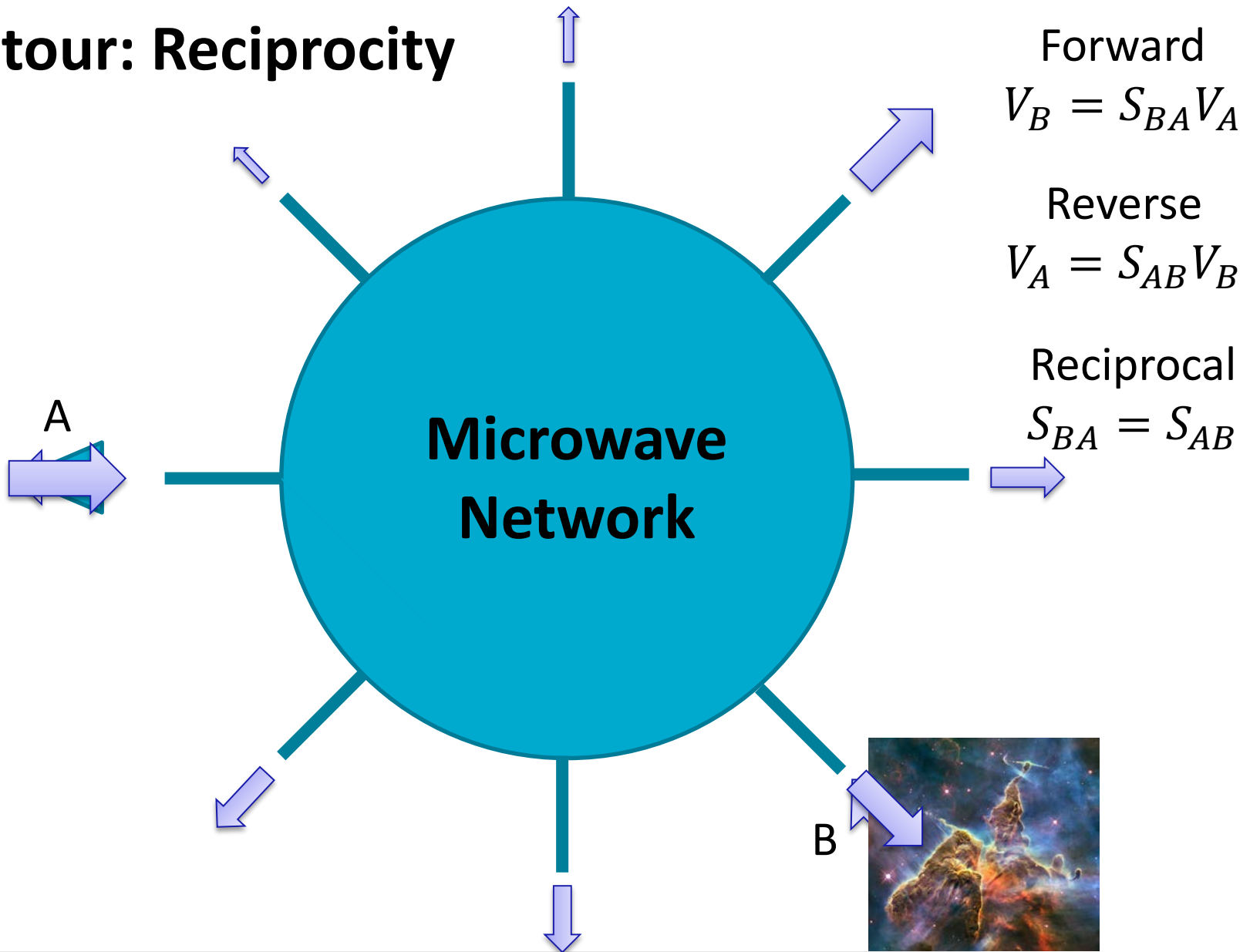

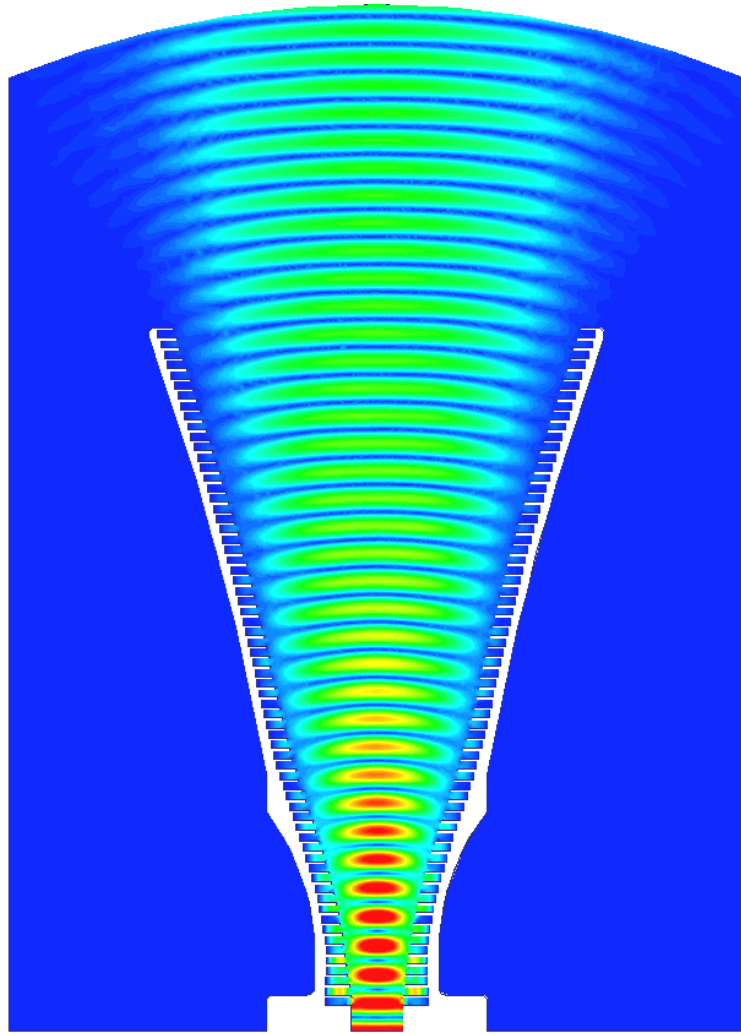

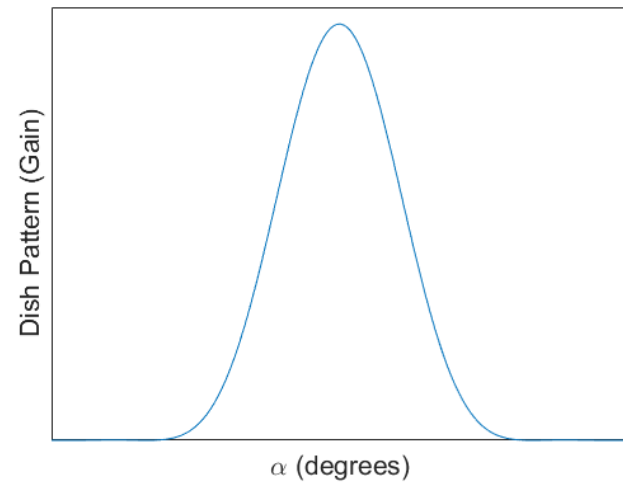
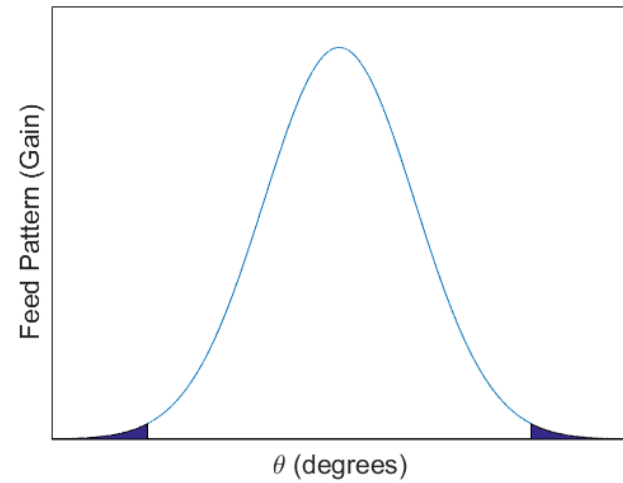
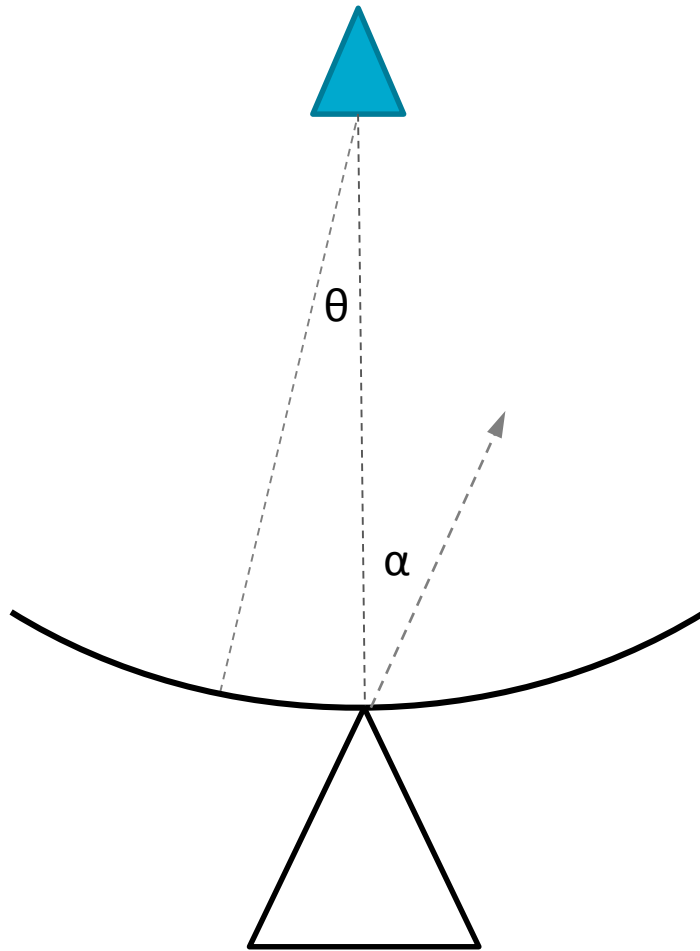

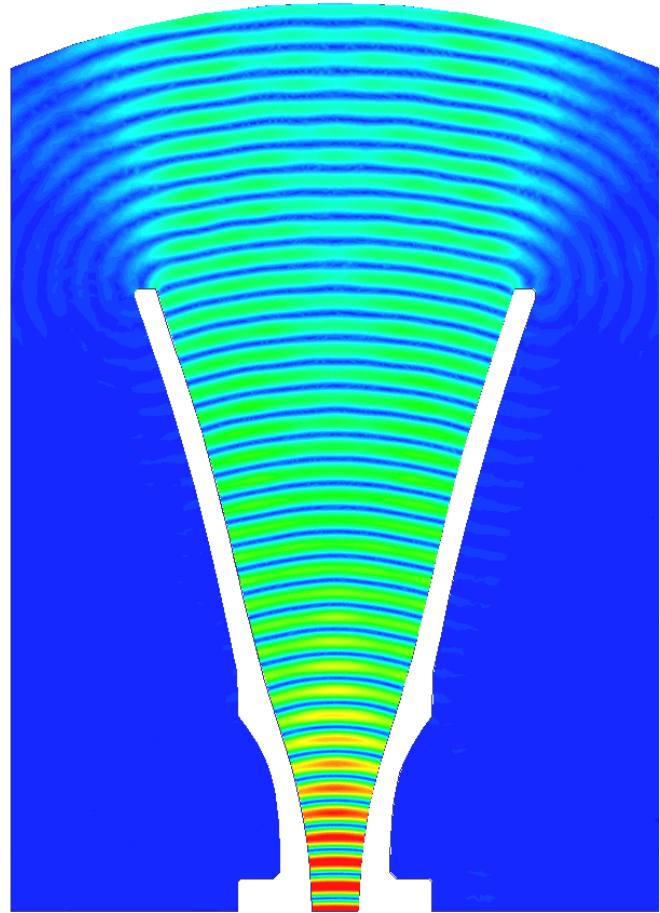
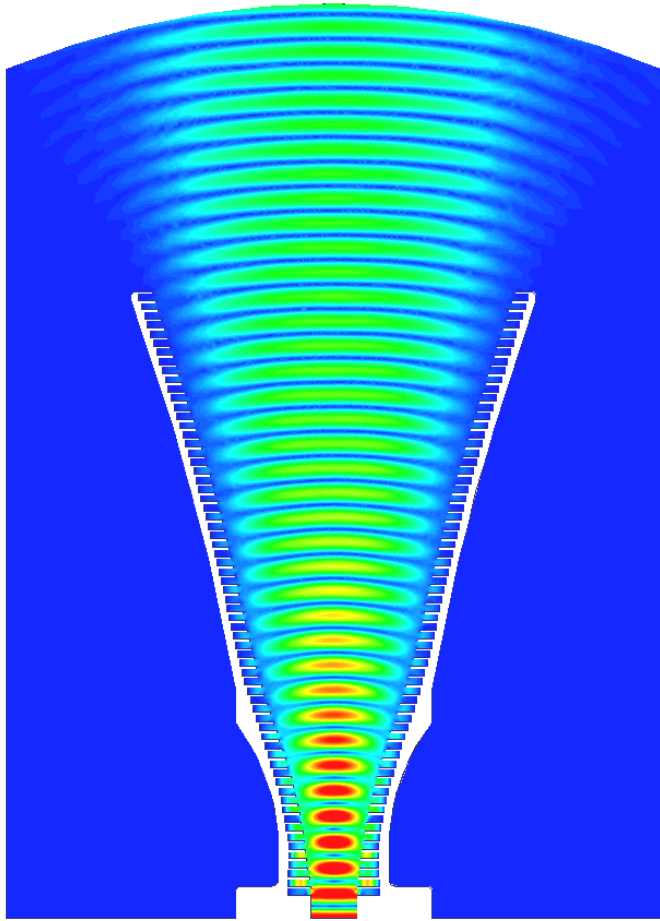

Corrugated

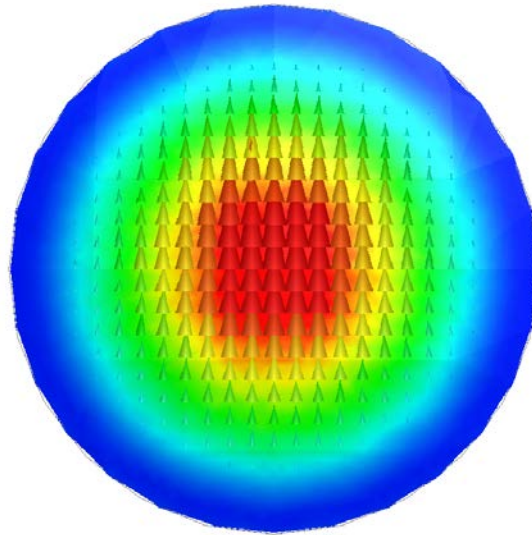

E-Field At
Feed mouth

Smooth Walled

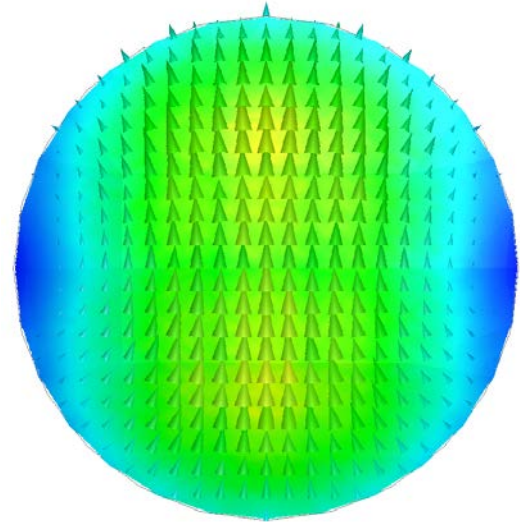

X and Y Feed
Patterns

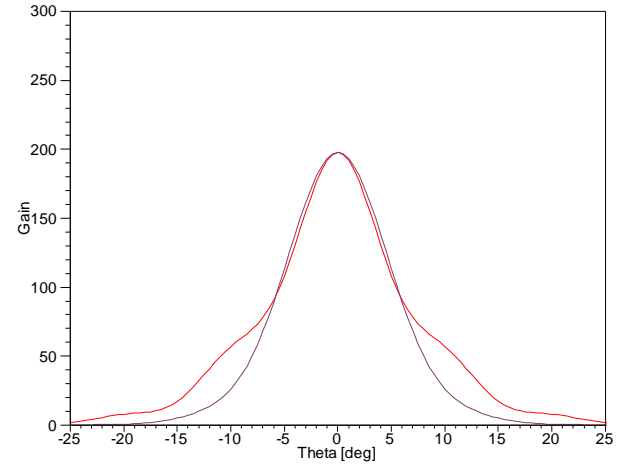
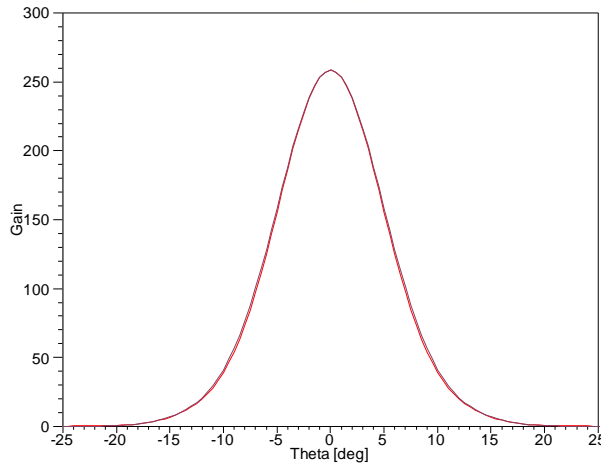

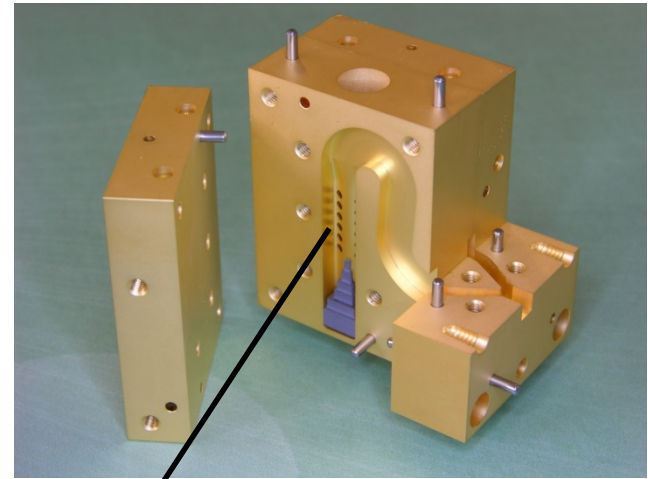
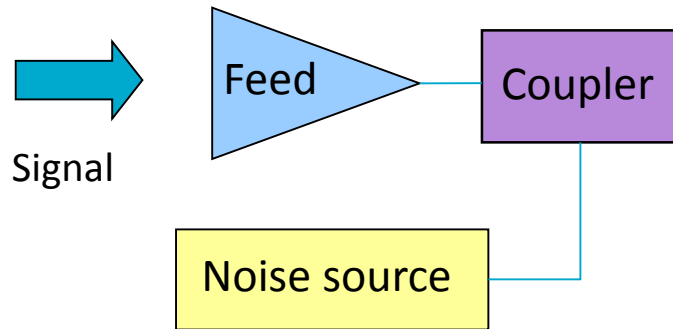

Noise coupled in through small holes

7mm waveguide coupler

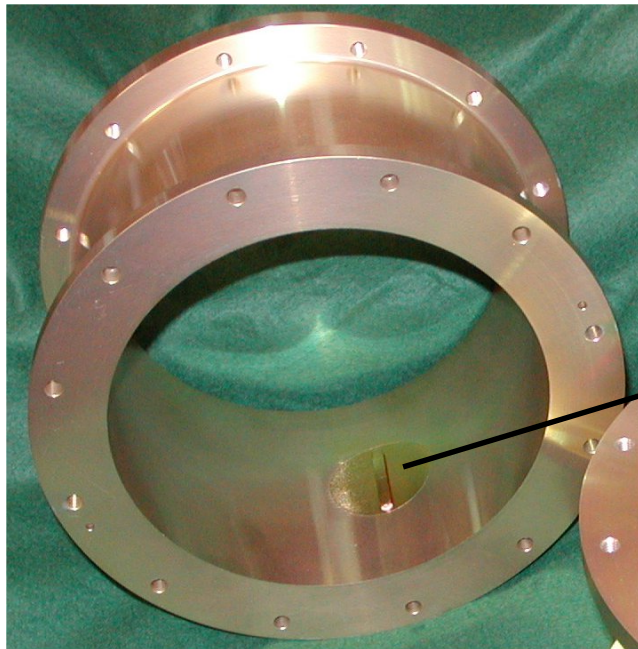

Noise coupled in through vane

21cm waveguide coupler



12mm noise source

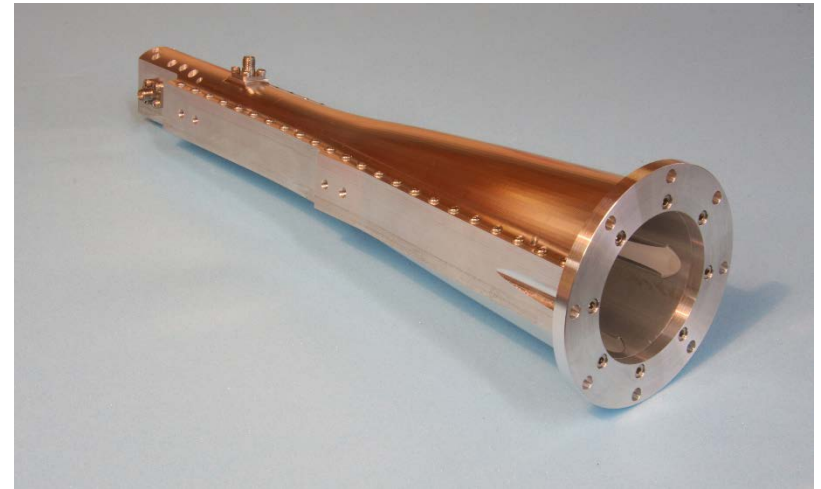
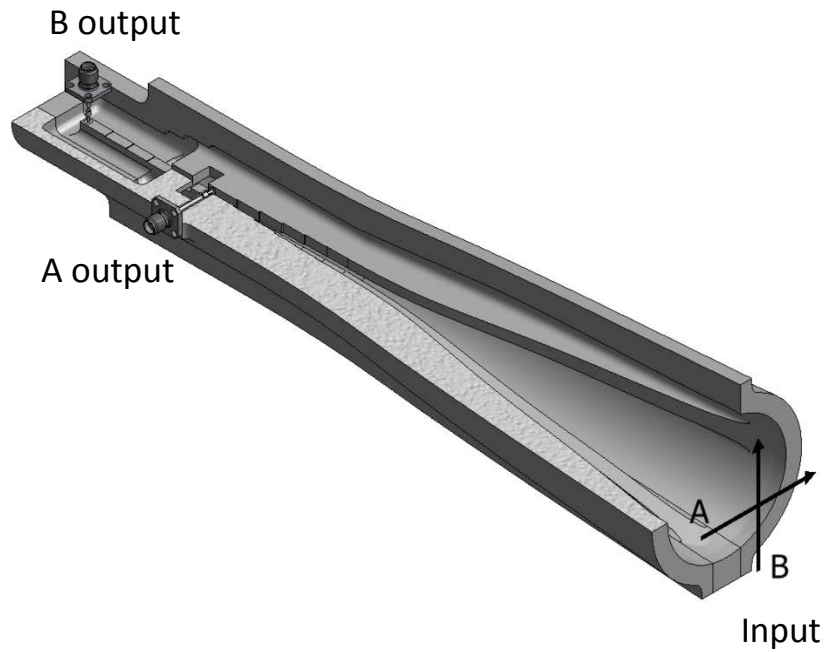
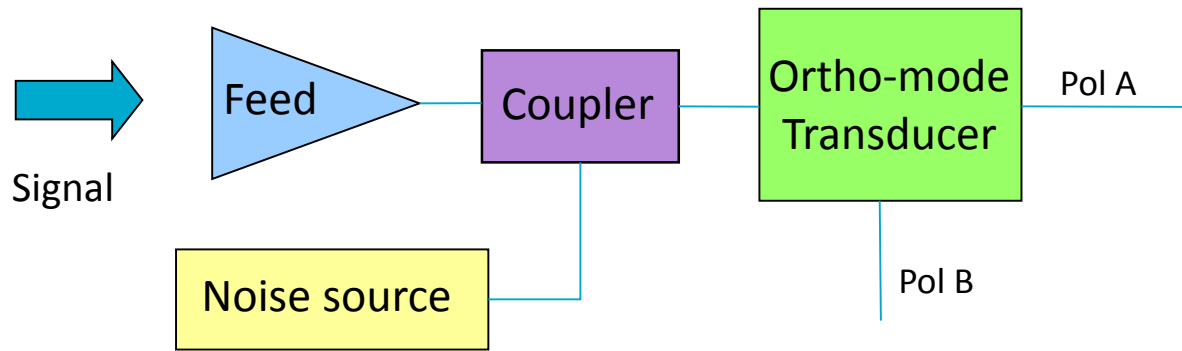

Separating the Polarisations: The OMT

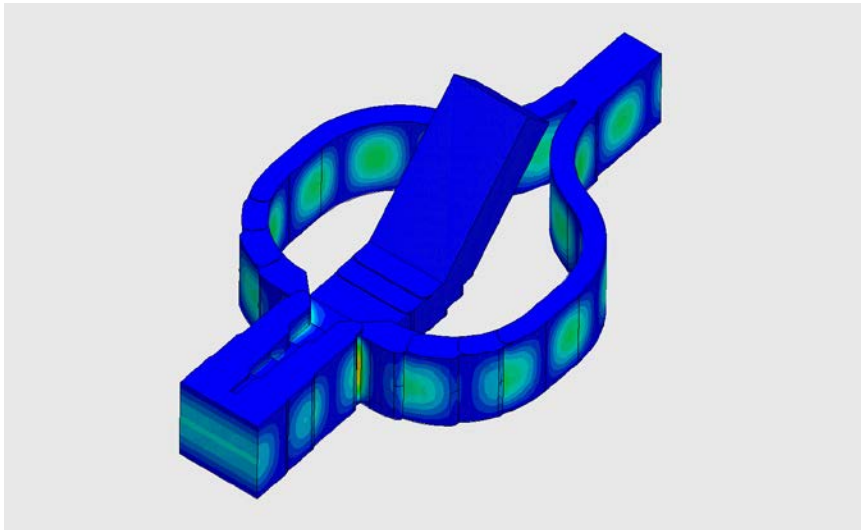
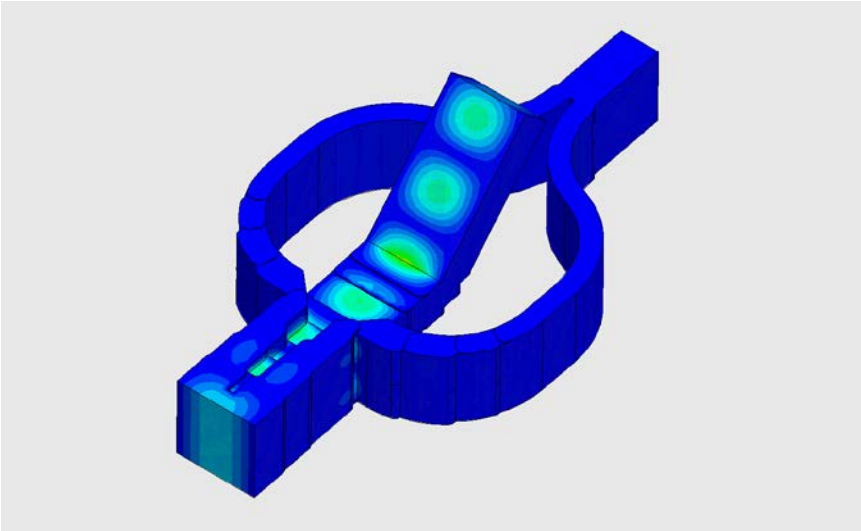
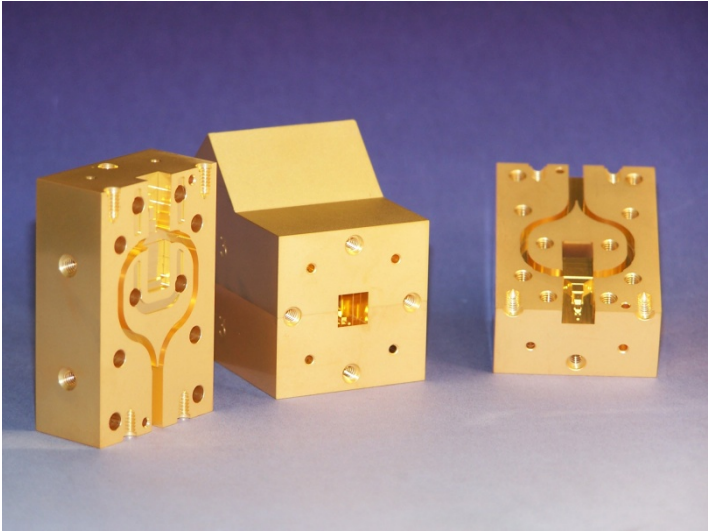

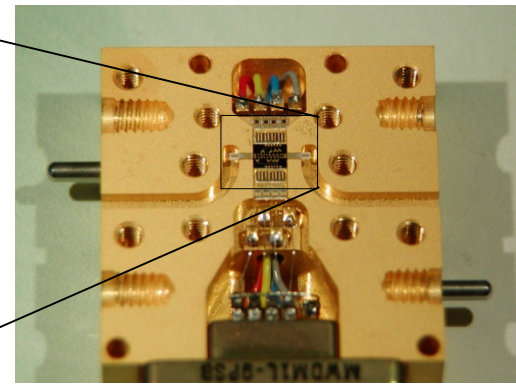
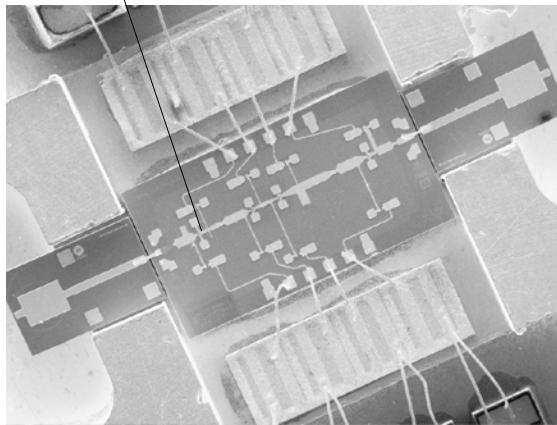
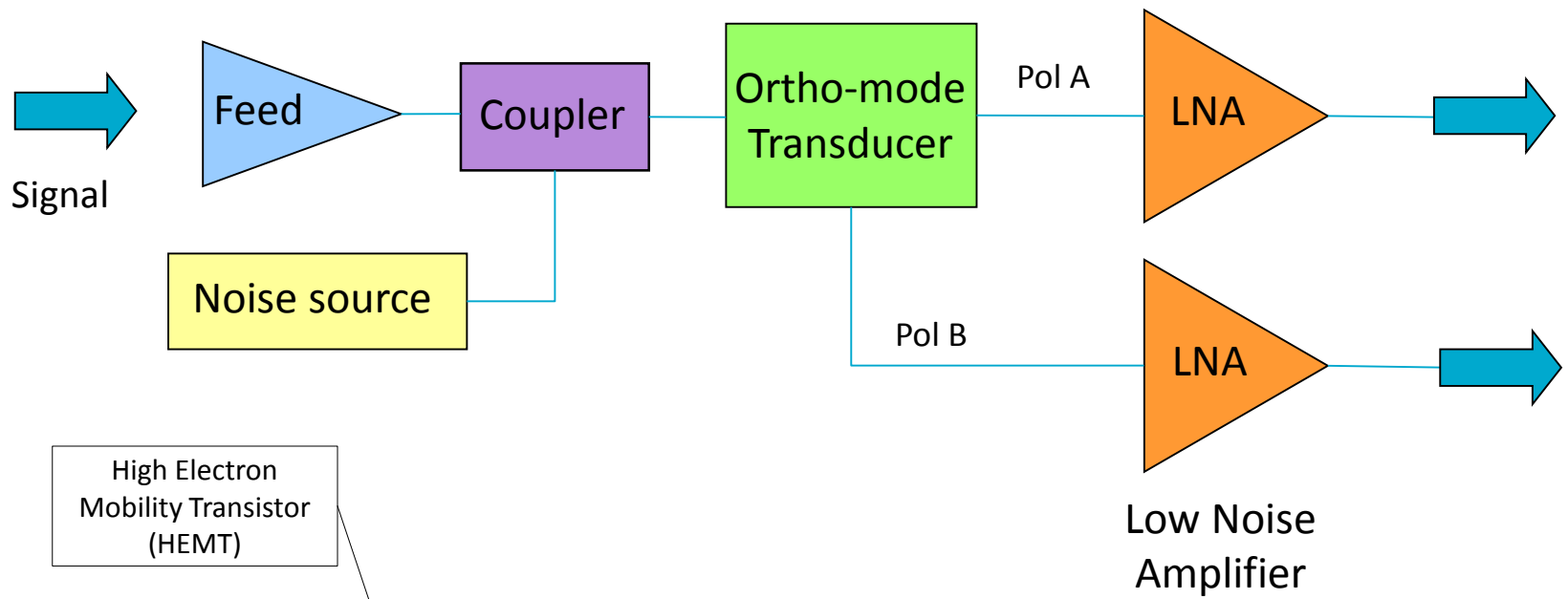

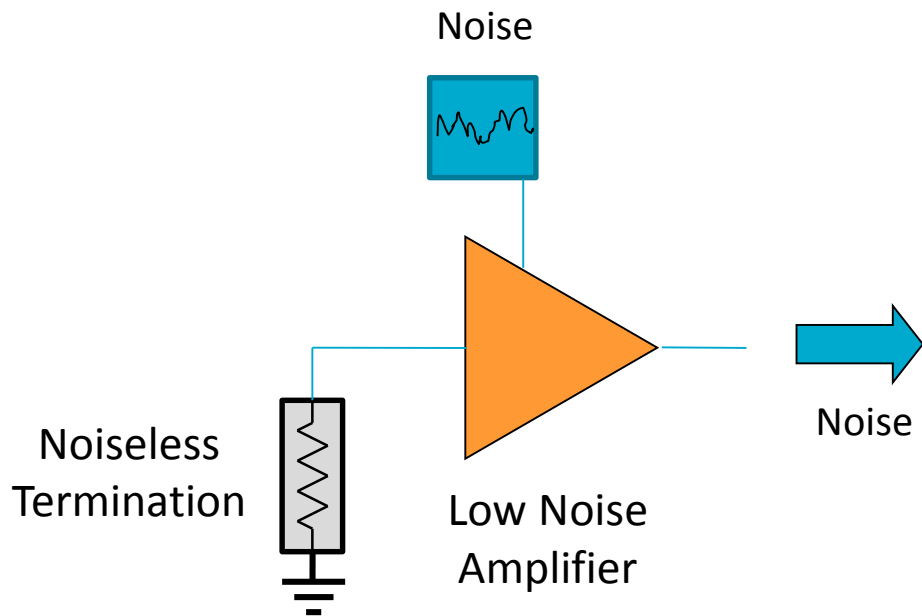

$$P_{output} \propto Gain \Delta f$$

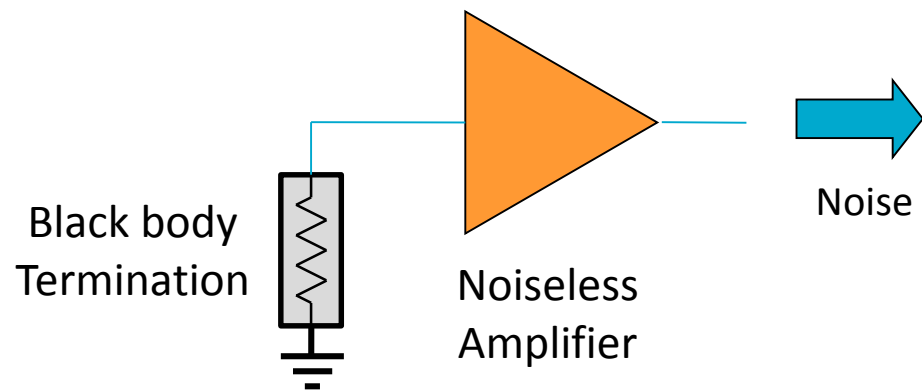

$$P_{output} = Gain \Delta f k_B T_{resistor}$$

$$T_{equivalent} = \frac{P_{output}}{Gain \Delta f k_B}$$

$$T_{system} = T_1 + \frac{T_2}{Gain_{LNA}} + \frac{T_3}{Gain_{LNA} \times G_2} + \frac{T_4}{Gain_{LNA} \times G_2 \times G_3} \dots\dots$$

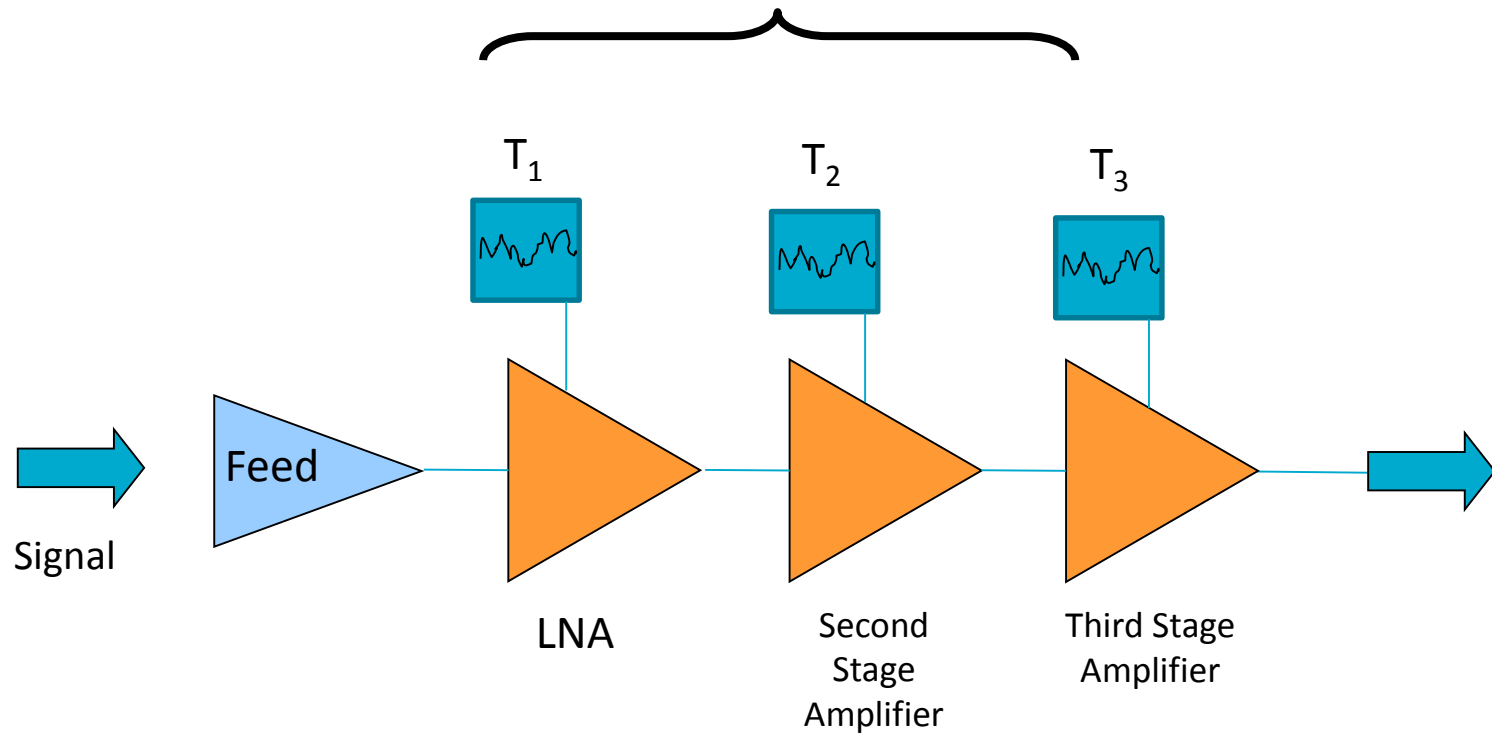

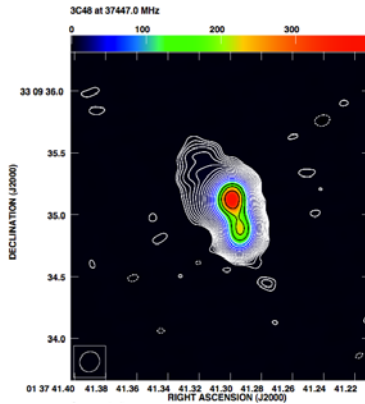

10Jy radio source \rightarrow $\sim 1\text{K}$ additional noise



Your hand \rightarrow $\sim 300\text{K}$ additional noise



Mobile Phone at 1 km \rightarrow $\sim 1 \times 10^{11}$ K !!
(in primary beam)

Noise contributions of a typical receiver

Part	Room Temperature	Cryogenic	Ratio
Sky + CMB (T_{sky})	6K	6K	1
Spillover (T_{spill})	3K	3K	1
Feed + OMT	10K	2K	5
LNA (T_{lna})	35K	5K	7
Rest of the System	1K	1K	1
Total (T_{sys})	55K	17K	~3

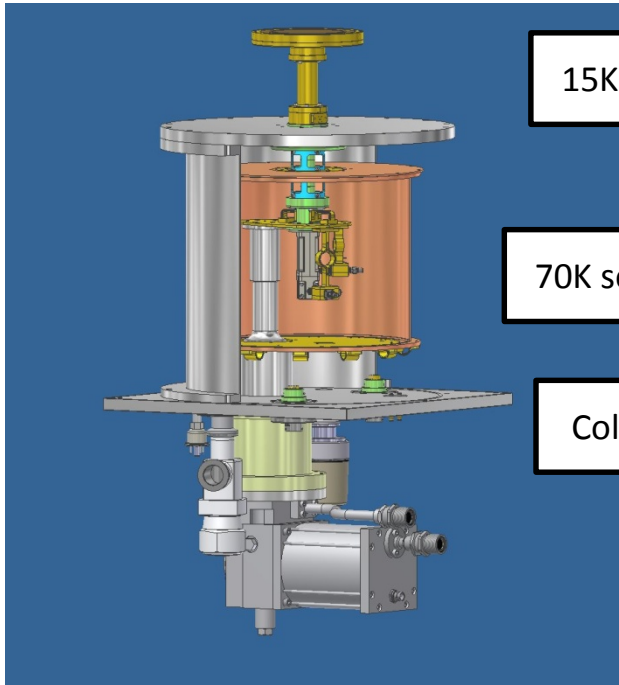

Refrigerator in the Parkes
12mm receiver

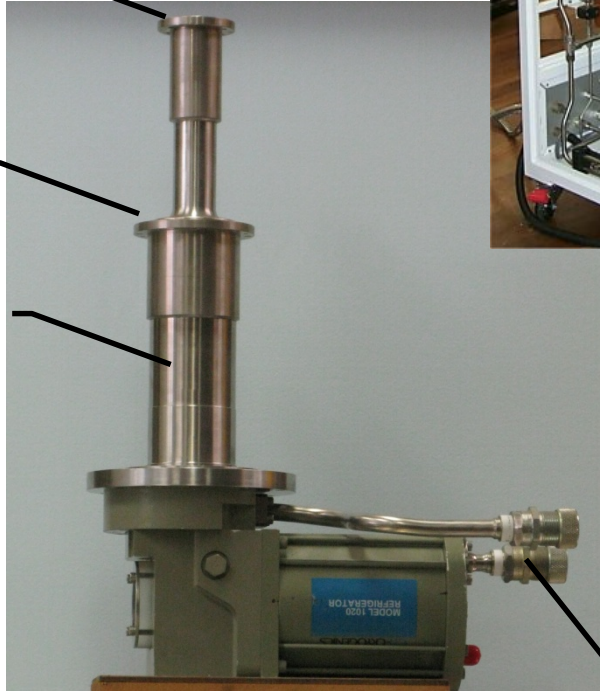

Helium Refrigerator



Helium Compressor

Helium Lines

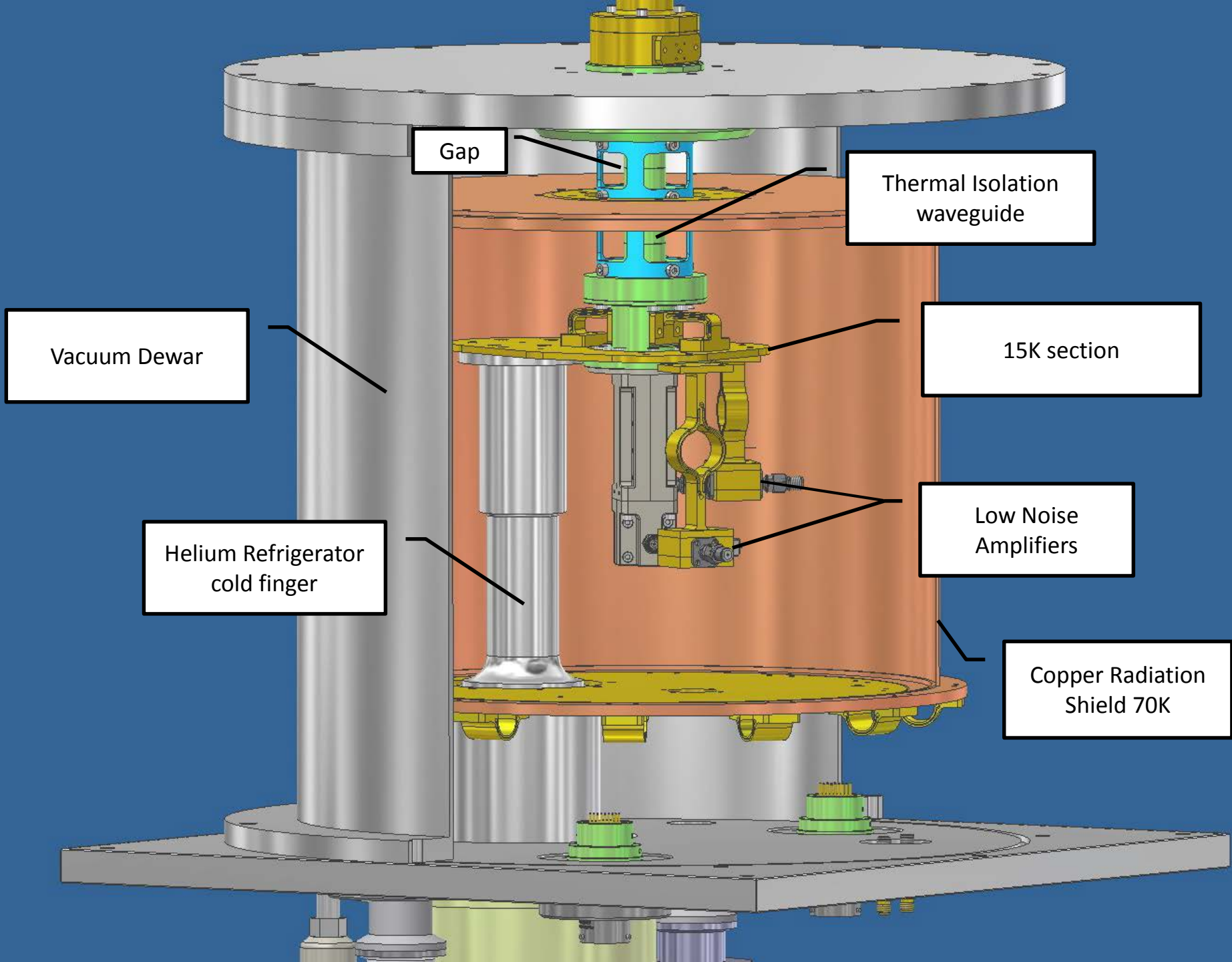

The RF System

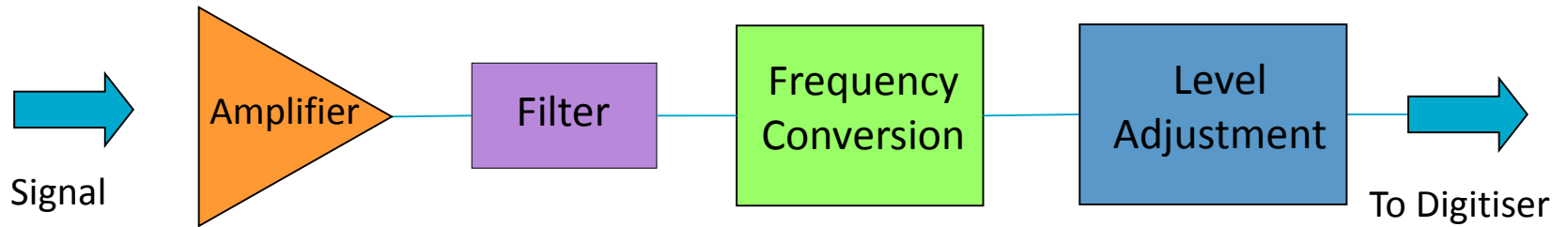

Contains:

- More amplification
- Band defining filters
- Frequency conversion
- Level adjustment
- Signal detection
- Band shaping

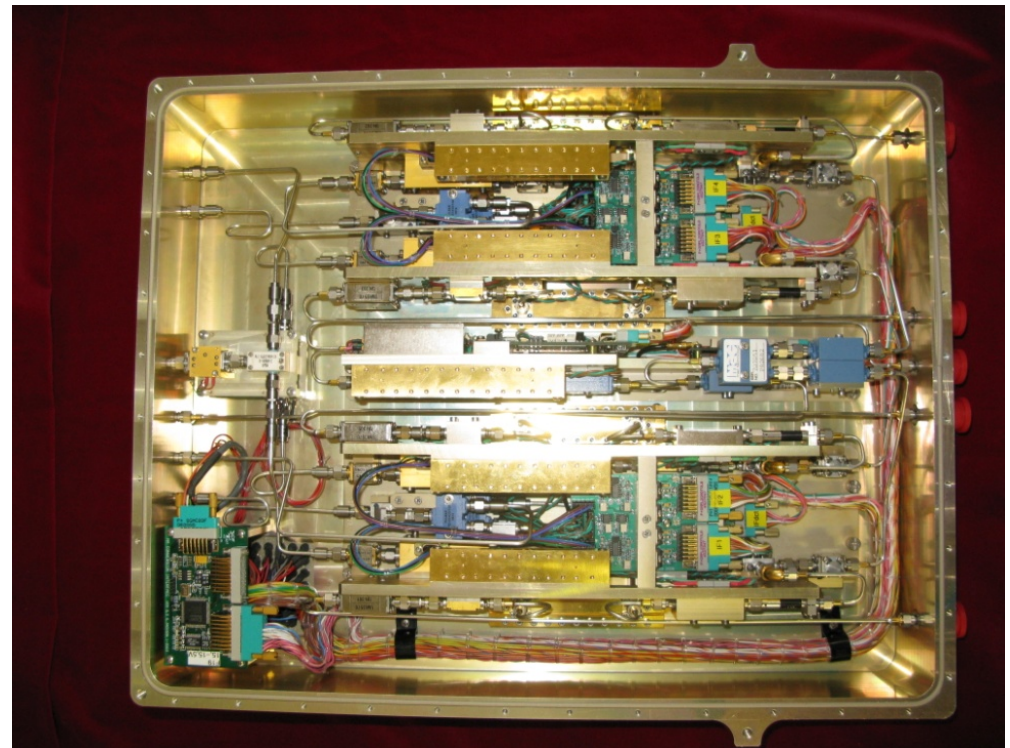

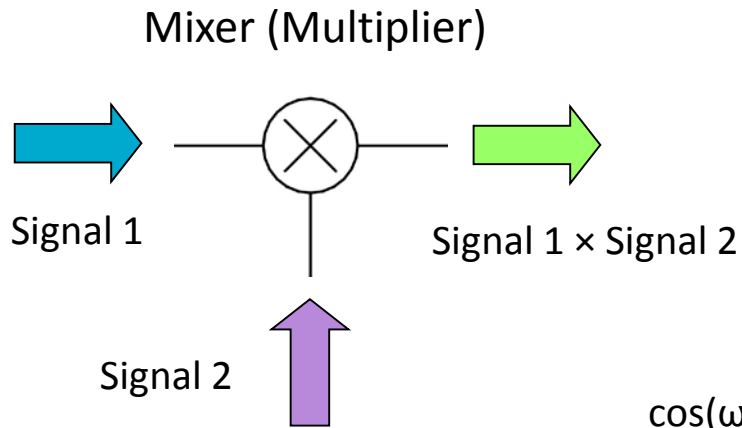

$$\cos(\omega_1 t)\cos(\omega_2 t) = \frac{1}{2}[\cos((\omega_1 + \omega_2)t) + \cos((\omega_1 - \omega_2)t)]$$

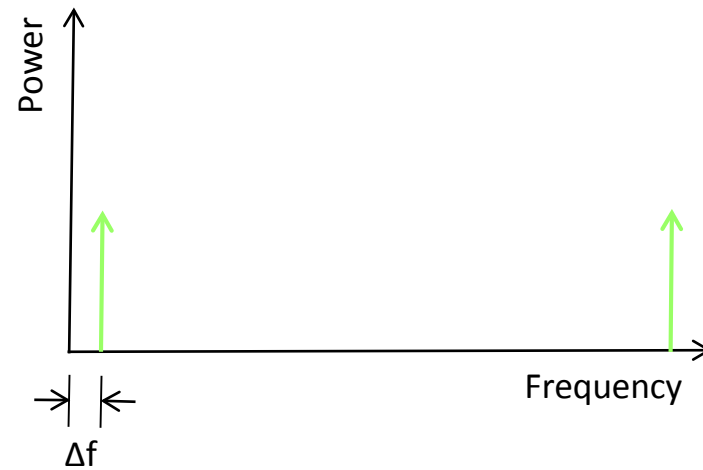
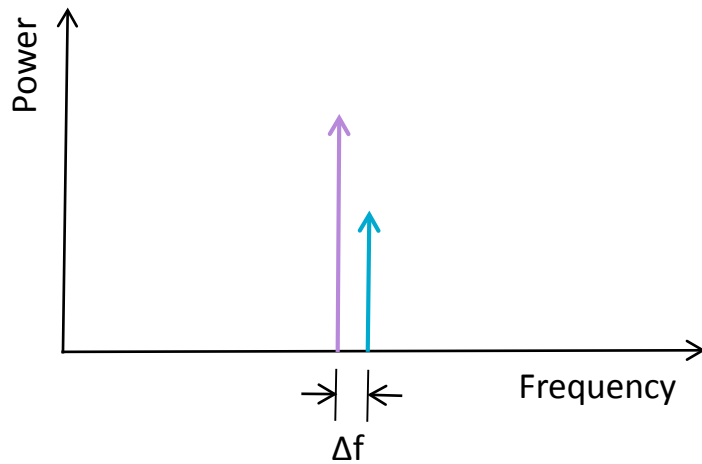

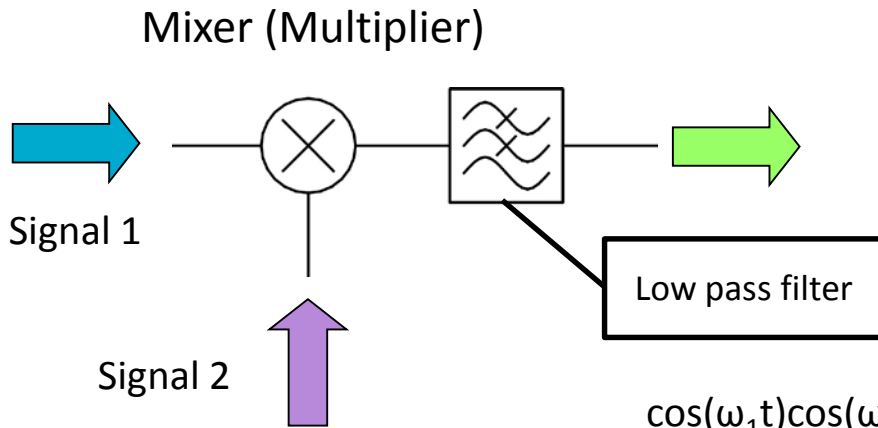

$$\cos(\omega_1 t)\cos(\omega_2 t) = \frac{1}{2}[\cos((\omega_1 + \omega_2)t) + \cos((\omega_1 - \omega_2)t)]$$

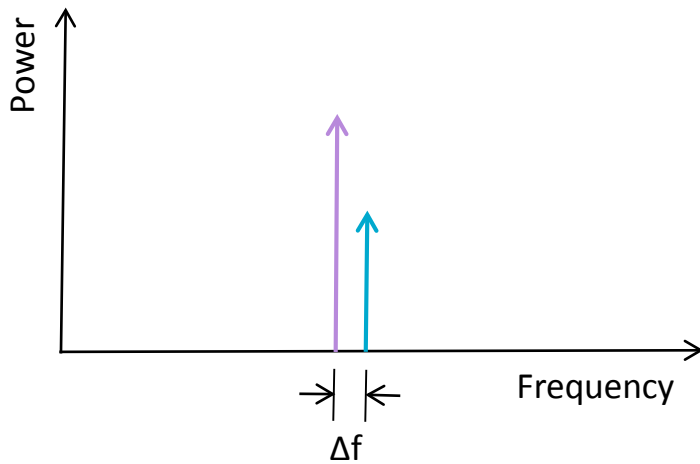
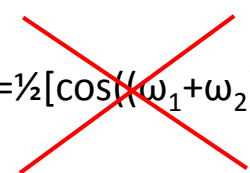

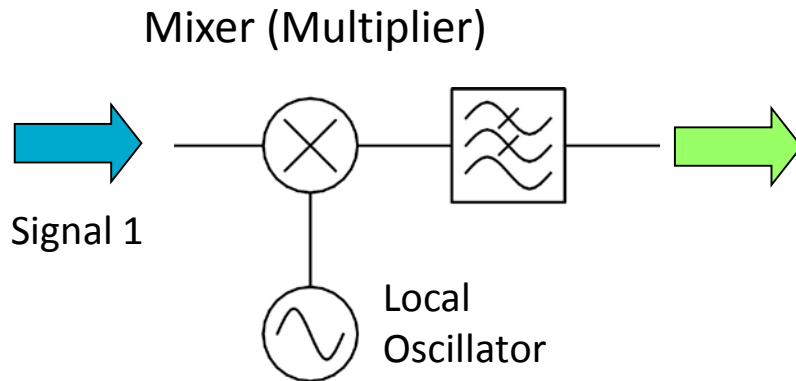

$$\cos(\omega_1 t)\cos(\omega_{LO} t) \rightarrow \frac{1}{2}\cos[(\omega_1 - \omega_{LO})t]$$

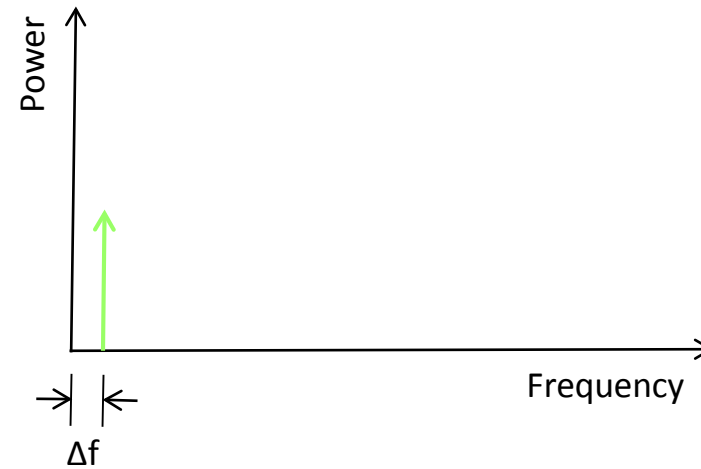
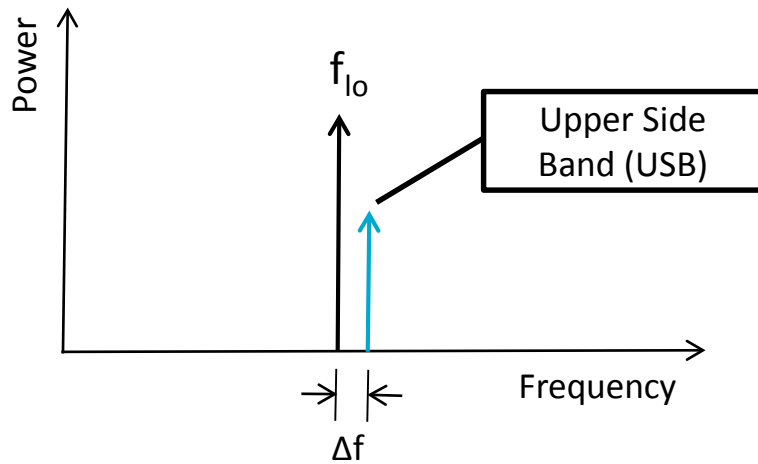

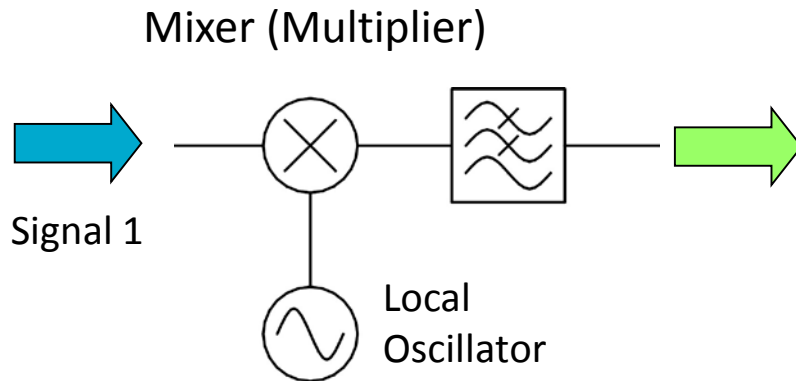

$$\cos(\omega_1 t)\cos(\omega_{LO} t) \rightarrow \frac{1}{2}\cos[(\omega_{LO}-\omega_1)t]$$

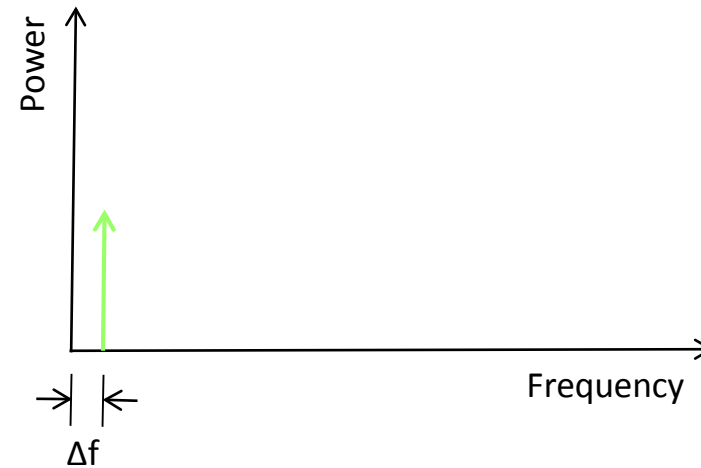
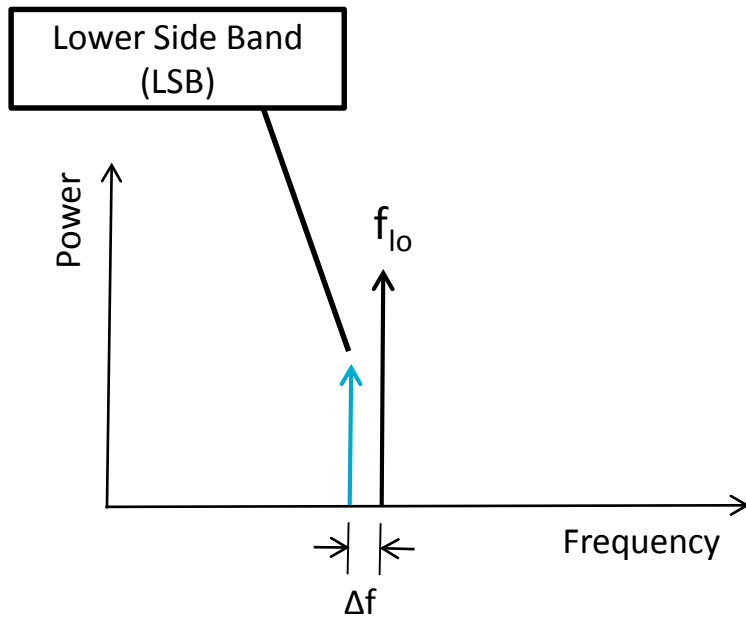

Mixer (Multiplier)

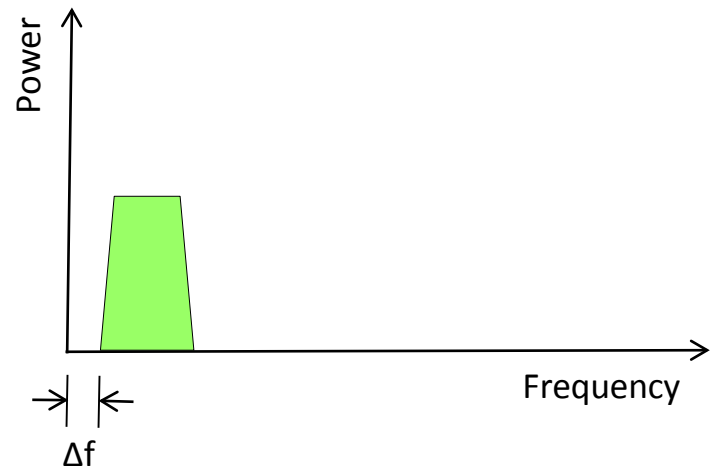
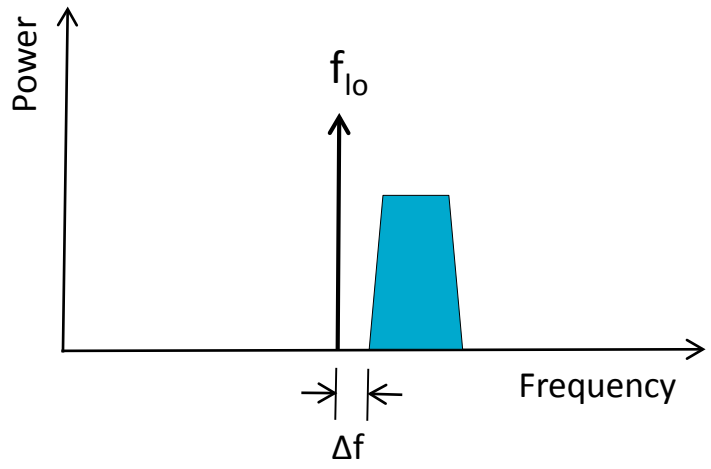
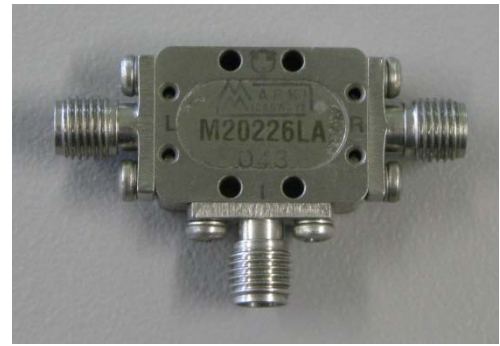
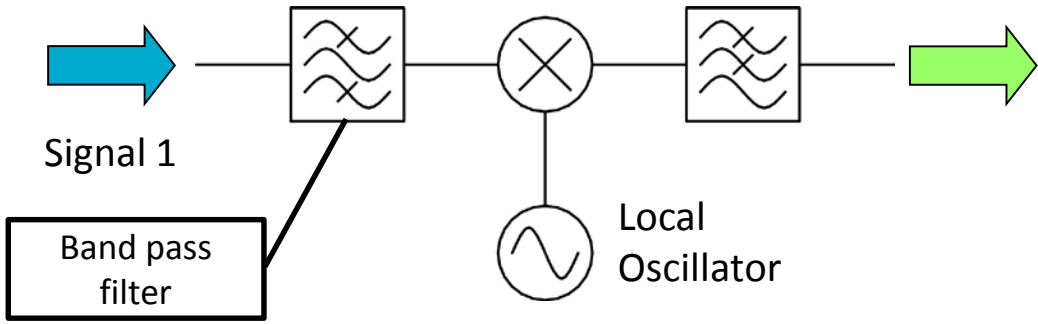

The modern radio telescope 0.000001 megapixels

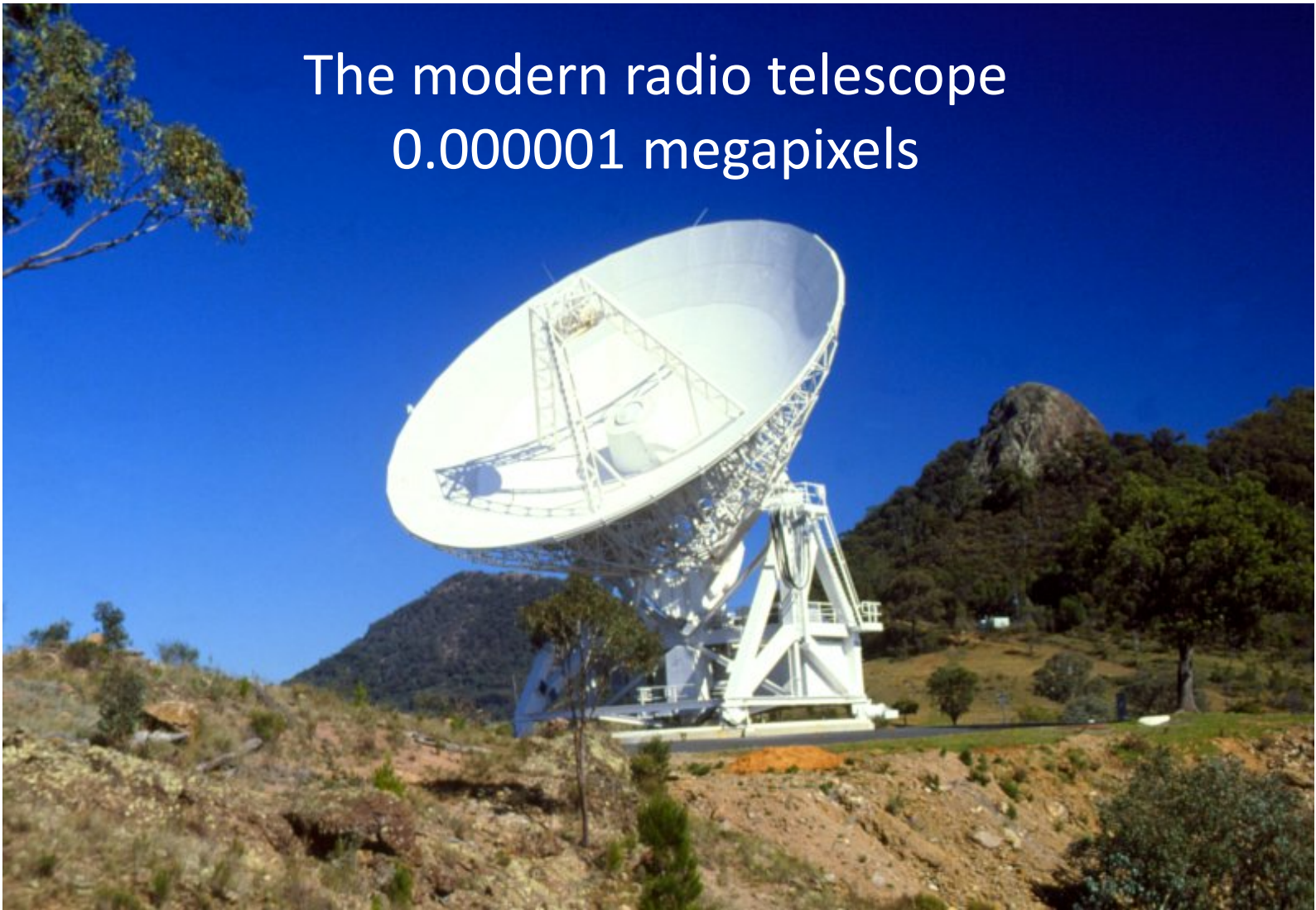

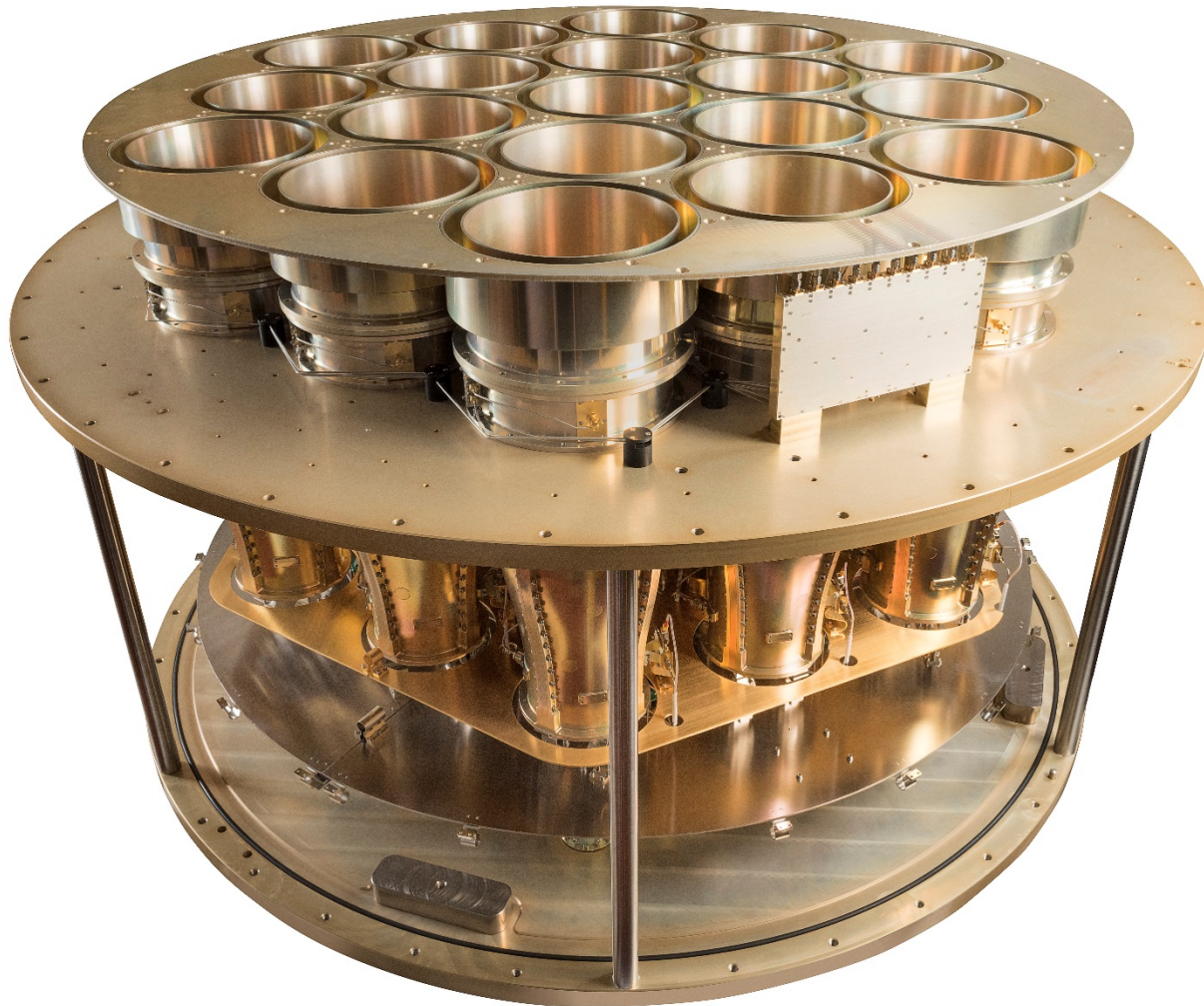
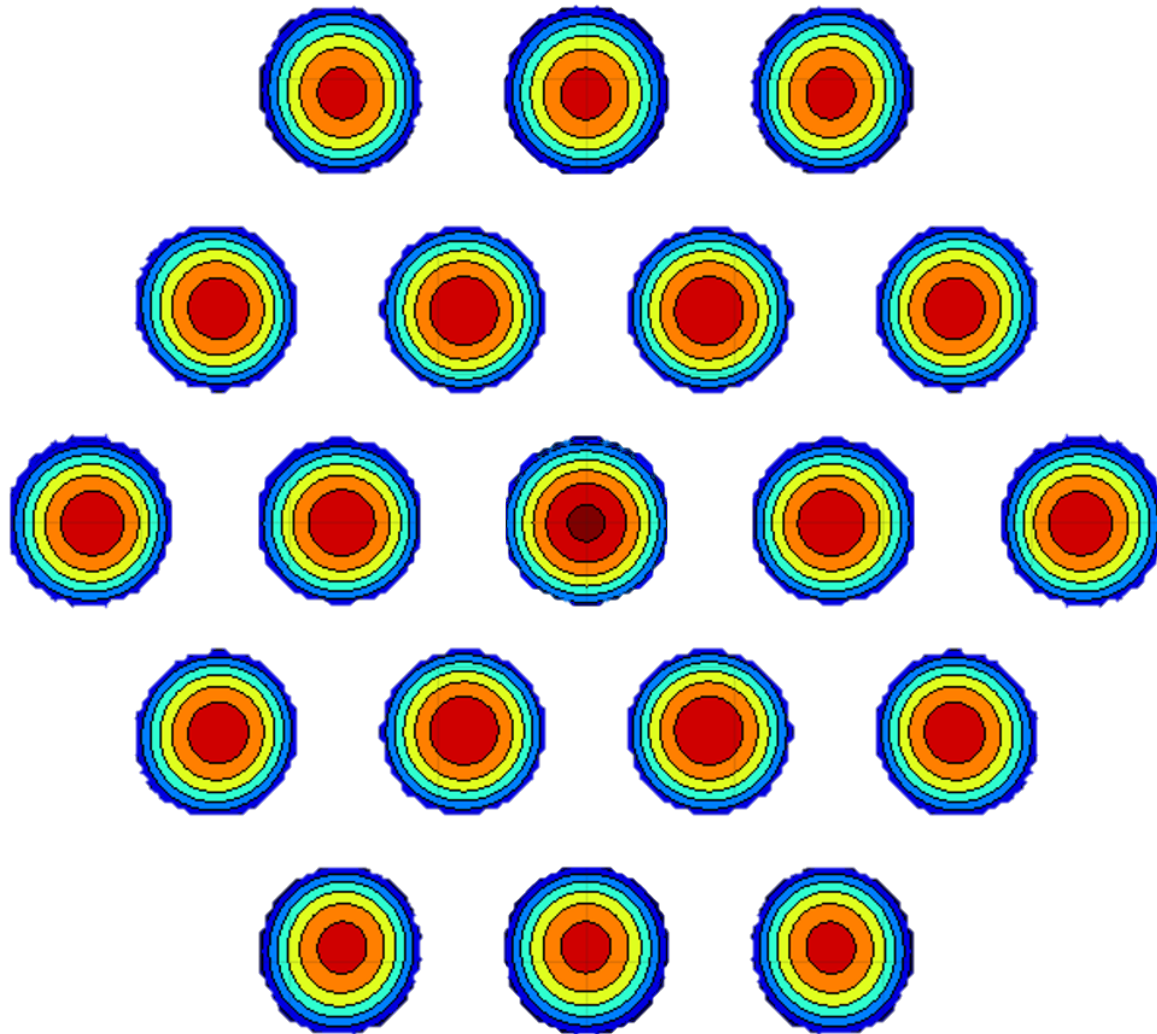
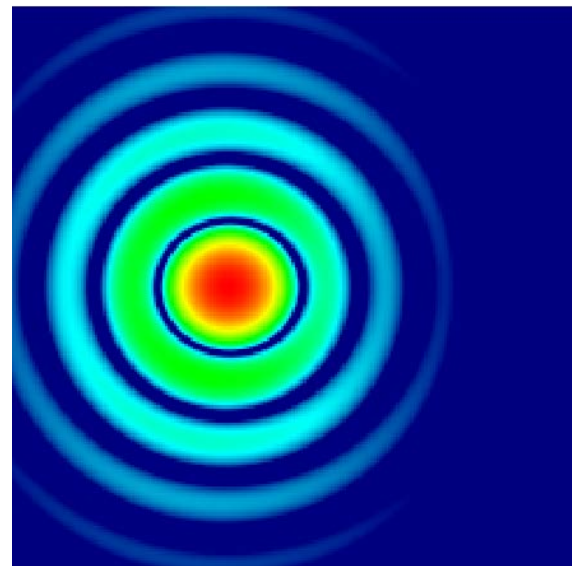
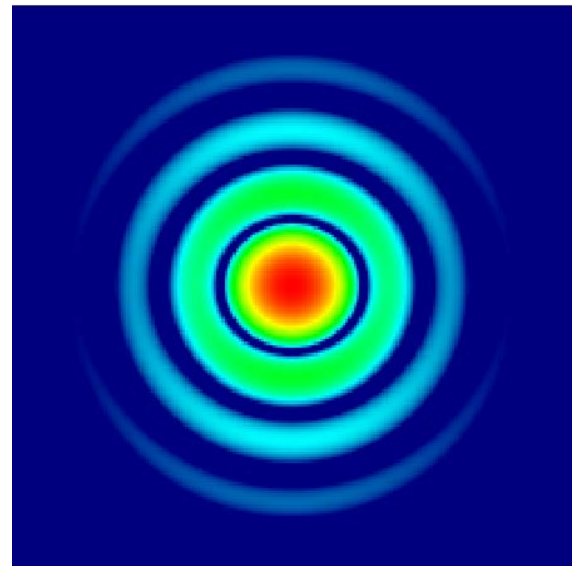
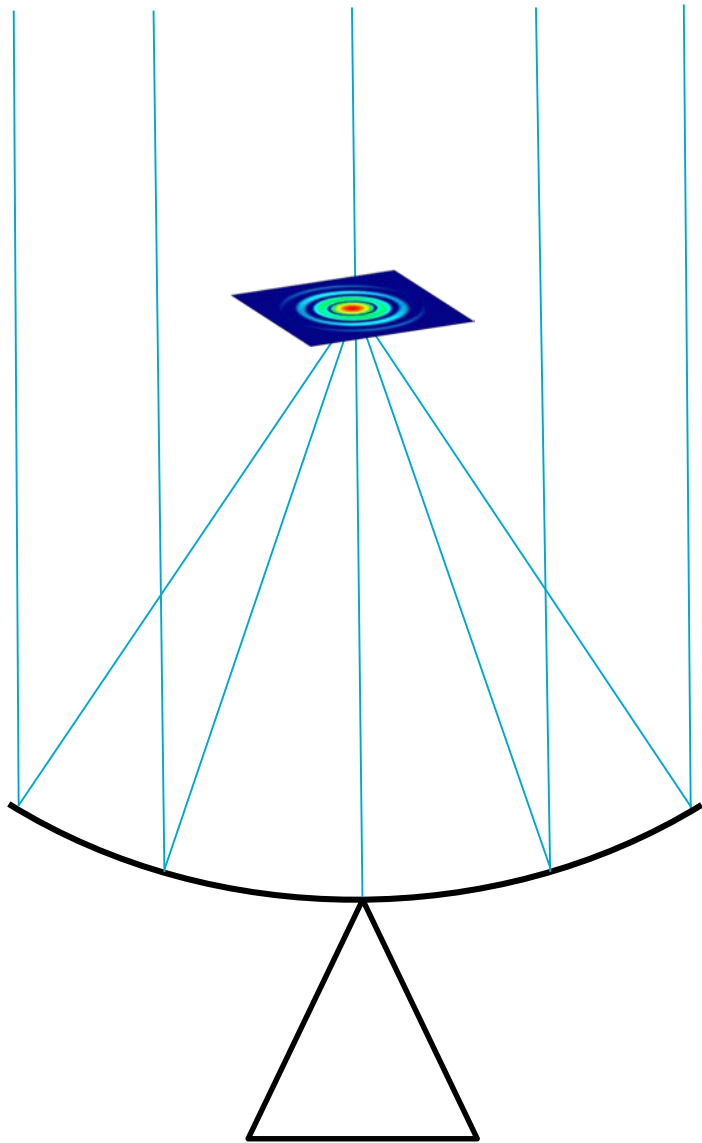
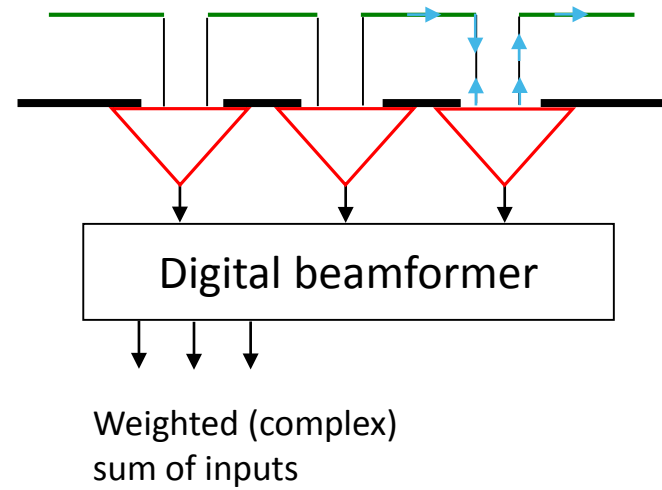
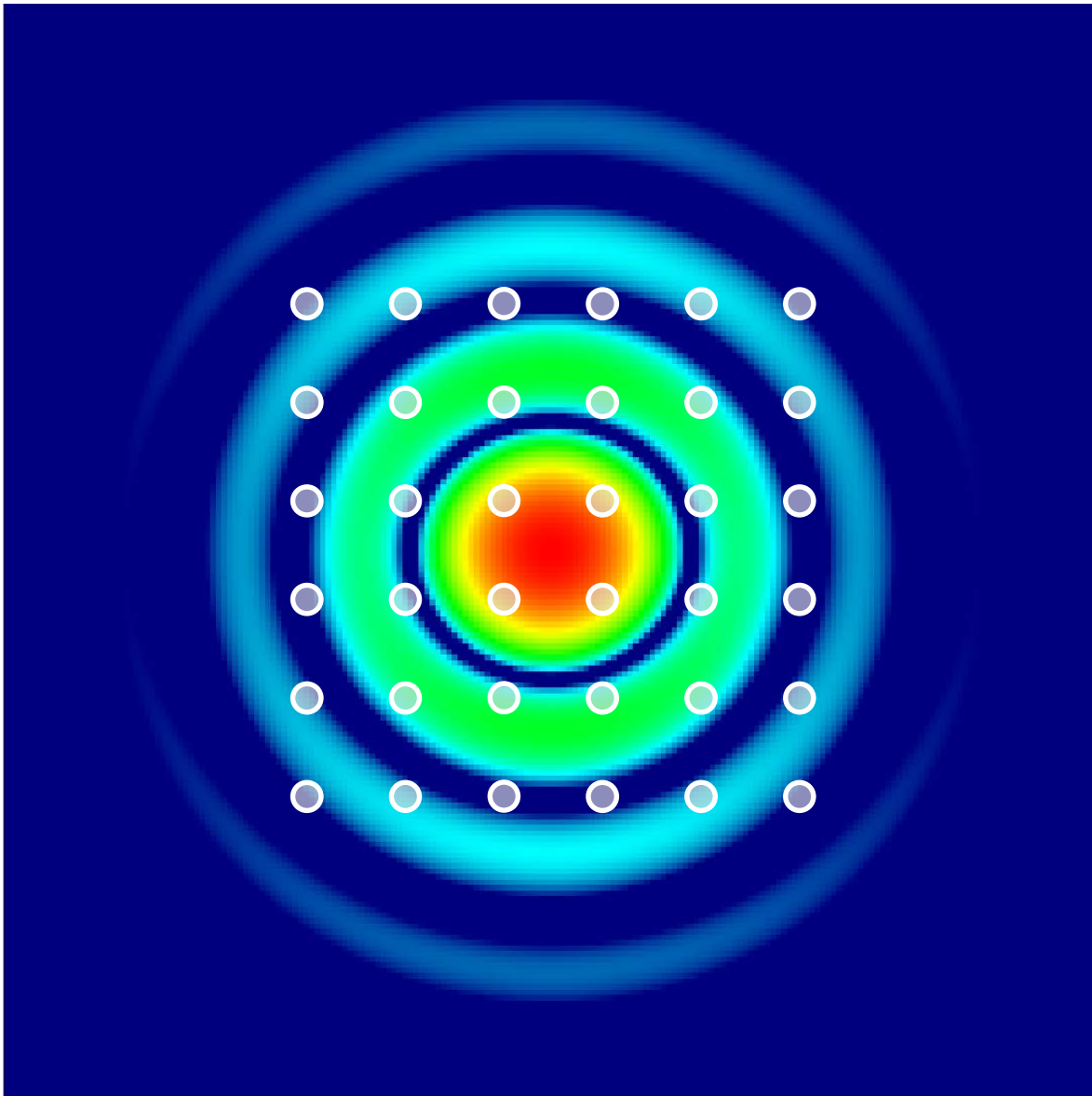
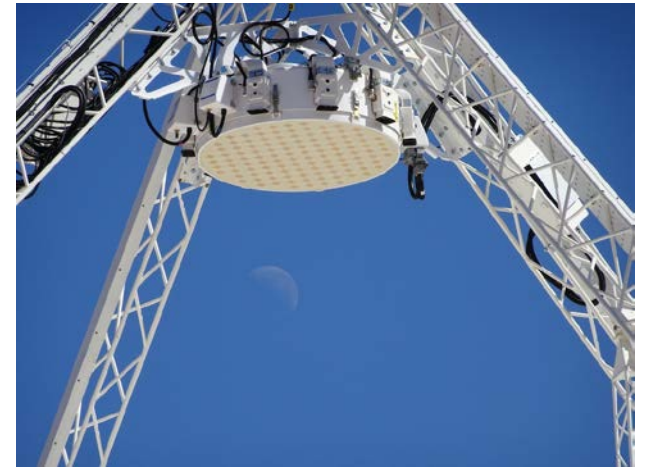
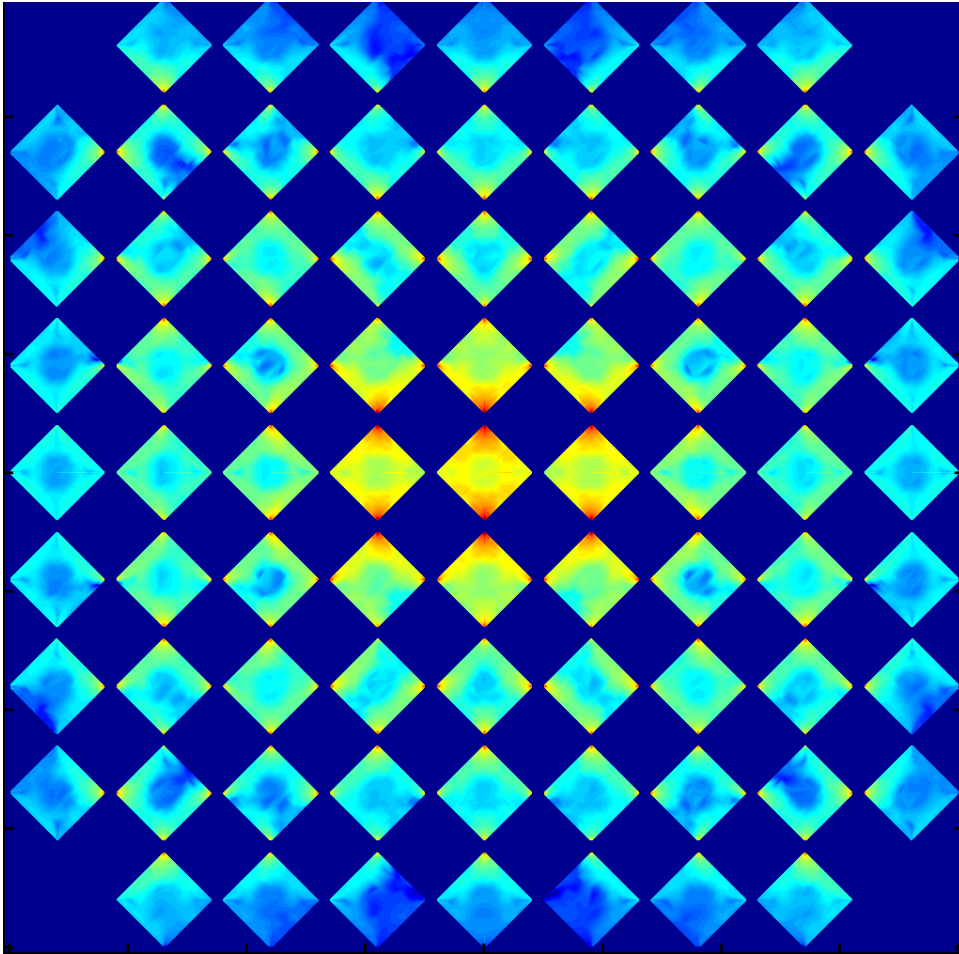

Photo credit: Wheeler Studios











Thank you

CSIRO Astronomy and Space Science
Alex Dunning

t +61 2 9372 4346
e alex.dunning@csiro.au
w www.csiro.au/cass

CSIRO ASTRONOMY AND SPACE SCIENCE
www.csiro.au

